

JOB NAME:	
CONTRACTOR:	DATE:
CAMO® WEDGEMETAL™ FOR METAL JOISTS	



Size: #7 x 2-in
Head Type: Trim
Drive Type: T15 Star
Point Type: Drill Point #2



APPLICATION For indoor or outdoor applications
 Designed for installation of grooved deck board materials on metal joists
 Drill Point #2 for materials up to 0.09-in thick

FEATURES Features black coating for reduced visibility
 UV protected plastic clip
 Clip covers and hides joist visibility
 Gusset designed for high holding power
 Screw remains accessible for easy removal

MATERIALS 304 Stainless Gusset
 410 Stainless Screw
 Nylon Plastic Spacer Body

COATINGS Black coating over 304 Stainless meets ASTM B117 for salt spray corrosion testing
 Black coating over 410 stainless meets ASTM B117 for salt spray corrosion testing

INSTALLATION Not recommended for use with impact drivers

CAUTION Not recommended for use with aluminum joists, due to galvanic corrosion
 Not intended for side wall applications



Deck boards have many different shapes forming the grooves used for clip attachment. Shape variations may include rounded corners and slightly angled grooves. The steeper these angles, the less effective pre-installation will be. The deeper the groove extends into the board, the higher the risk of board damage from overtightening the screw.

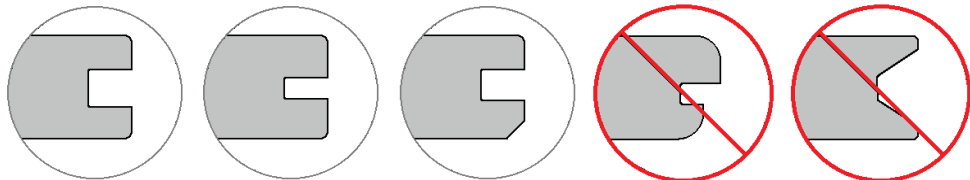

PENETRATION DEPTH MINIMUM deck board groove should be 1/8" tall x 1/4" deep. The material remaining below groove (dim A) must be at least 1/4". The bottom of the plastic part of the clip is not designed to contact the joist. See image to the right for a visual representation of the clip's gusset and screw.

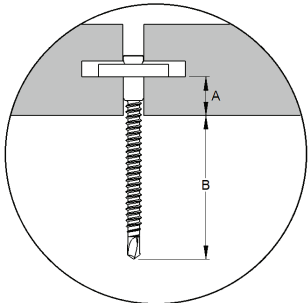

Dimension A	Dimension B
1/4 in	1-1/2 in
3/8 in	1-3/8 in
1/2 in	1-1/4 in

CAMO® WEDGEMETAL™ FOR METAL JOISTS

FASTENER DIMENSIONS

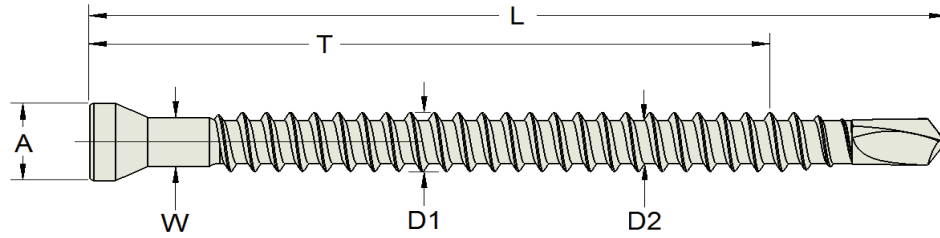

Head Dia.	Major Thread Dia.	Minor Thread Dia.	Overall Length	Shank Dia.	Thread Length
A	D1	D2	L	W	T
∅ 0.200 in	∅ 0.150 in	∅ 0.112 in	2 in	∅ 0.125 in	1-1/2 in

DIRECTIONS

Tilt clip back slightly from deck board and place the tips of the fingers into the groove. Press down to compress the fingers enough to rotate the clip vertical so the gusset also enters the groove. Take care to place it so there is a joist board directly underneath. Repeat for each joist along the length of the deck board. Place the next deck board in position and slide against the clips. The groove should slip over the exposed gusset on the clips. Maintain steady pressure on deck board while securing the screws. While the CAMO LEVER® tool maintains this steady pressure, use a standard screw gun, the included T15 drive bit, and the included NEVER-MISS® Guide to secure the screw to the joist. For the most efficient installation, use the CAMO DRIVE® tool or CAMO ClipDRIVE® tool (each sold separately).



Never Miss Guide
(included in 450 ct.)

CAMO LEVER
#0345070

AVAILABLE PRODUCT



SKU	Coverage	Drive Bit (QTY) Size	Box Count QTY	Master Pack
0344674	50 ft ²	(1) T15	90 ct	8 pack
0344679	250 ft ²	(1) T15	450 ct	1 pail

COMPATIBLE TOOLS

CAMO DRIVE
#0345060



CAMO ClipDRIVE
#0345065

