

JOB NAME:	
CONTRACTOR:	DATE:



CAMO® EDGEXMETAL™ FOR METAL JOISTS

Size: #7
Head Type: Trim
Drive Type: T15 Star
Point Type: Drill Point #2



APPLICATION For indoor or outdoor applications
 Designed for installation of grooved deck board materials on metal joists
 Drill Point #2 for 0.09 in maximum material thickness

FEATURES Features black coating for reduced visibility
 UV protected plastic clip
 Clip covers and hides joist visibility
 Gusset designed for high holding power
 Screw remains accessible for easy removal

MATERIALS 304 Stainless Gusset
 410 Stainless Screw
 Nylon Plastic Spacer Body

COATINGS Black Zinc over 304 Stainless meets ASTM B117 for salt spray corrosion testing
 Black ecoat over 410 stainless steel is compatible with chemically treated lumber
 Stainless Steel screws are passivated per ASTM A380 standard

SPECIFICATIONS Uplift Test per ICC-ES AC174 performed by Intertek (Report K7416.01-119-19)
 UV Test per ASTM D2565 performed by Intertek (Report H6863.01-119-19)
 Lateral Load in Hot/Cold performed by Intertek (Report K7416.01-119-19)

INSTALLATION Not recommended for use with impact drivers

CAUTION



Not recommended for use with aluminum joists, due to galvanic corrosion
 Not intended for side wall applications
 Deck boards have many different shapes forming the grooves used for clip attachment. Shape variations may include rounded corners and slightly angled grooves. The steeper these angles, the less effective the EdgeXMetal pre-installation will be. The deeper the groove extends into the board, the higher the risk of board damage from overtightening the screw.

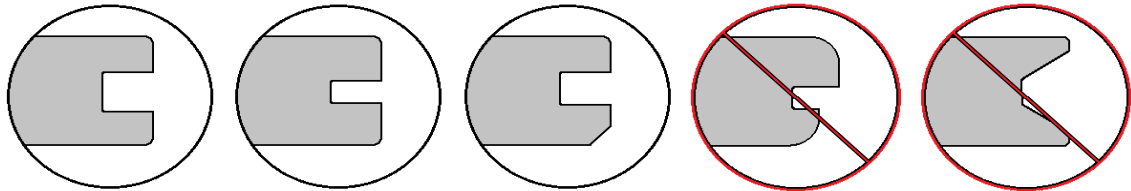

FASTENER DIMENSIONS

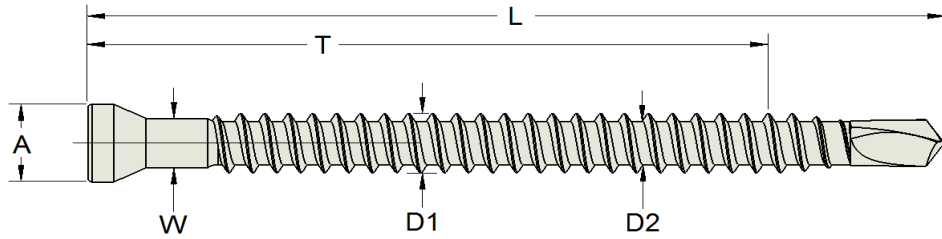

Head Dia.	Major Thread Dia.	Minor Thread Dia.	Overall Length	Shank Dia.	Grip Length
A	D1	D2	L	W	T
Ø 0.200 in	Ø 0.150 in	Ø 0.112 in	2 in	Ø 0.125 in	1-1/2 in

PENETRATION DEPTH

MINIMUM deck board groove should be 1/8" tall x 1/4" deep. The material remaining below groove (dim A) must be at least 1/4". The bottom of the plastic part of the clip is not designed to contact the joist. See image to the right for a visual representation of the EdgeClip.

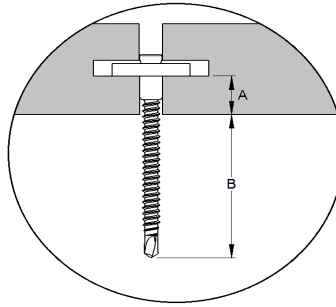

Dimension A	Dimension B
1/4 in	1-1/2 in
3/8 in	1-3/8 in
1/2 in	1-1/4 in

These values are valid for EdgeXMetal only.

PRODUCT AVAILABLE

	SKU	Coverage	Drive Bit (QTY) Size	Box Count QTY	Master Pack
	0344574	50 ft ²	(1) T15	90 ct	4 pack
	0344579	250 ft ²	(1) T15	450 ct	1 pack
DIRECTIONS	<p>Squeeze and slip wings of clip into the groove of deck board. Take care to place it so there is a joist board directly underneath. Repeat for each joist along the length of the deck board. Place the next deck board in position and slide against the clips. The groove should slip over the exposed gusset on the clips. Maintain steady pressure on deck board while securing the screws. Use a standard screw gun, the included T15 drive bit, and the included Never-Miss Guide. For the most efficient installation, use the CAMO Drive tool (sold separately).</p>				
(1) Never-Miss Plastic Guide in Every Box					