



**CAMO**<sup>®</sup>  
The Better Way to Build a Deck

# **TRAINING** **GUIDE** 2025



# TRAINING GUIDE

## CONTENTS

### FASTENING SYSTEMS



#### CLIPDRIVE™

STAND-UP DECK CLIP FASTENING SYSTEM

THE BETTER WAY TO FASTEN CAMO UNIVERSAL DECK CLIPS.

PAGES 4-7

FOR USE WITH CAMO UNIVERSAL DECK CLIPS



#### NEVER-MISS® GUIDE

DECK CLIP FASTENING SYSTEM

INCLUDED IN 450 CT AND 900 CT PAILS OF CAMO UNIVERSAL DECK CLIPS.

PAGES 8-17

FOR USE WITH CAMO UNIVERSAL DECK CLIPS



#### DRIVE

STAND-UP 3-IN-1 FASTENING SYSTEM

SAVE TIME WITH THE AWARD-WINNING CAMO DRIVE® TOOL.

PAGES 18-25

FOR USE WITH CAMO COLLATED EDGE + FACE SCREWS OR CAMO UNIVERSAL DECK CLIPS



#### MARKSMAN®

HIDDEN EDGE SCREW FASTENING SYSTEM

ACHIEVE A FASTENER-FREE SURFACE ON SQUARE EDGE DECKING.

PAGES 32-37

FOR USE WITH CAMO EDGE SCREWS

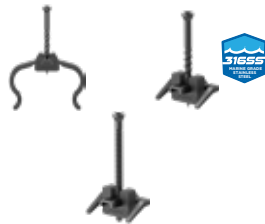

### ACCESSORIES

#### DECK TAPE

SELF-ADHESIVE LINED BUTYL TAPE



PAGES 38-39



#### BLOCK

THE BETTER FLOATING FOUNDATION

PAGES 40-43



PAGES 26-31 BOARD BENDING & LOCKING TOOL

#### ACCESSORIES

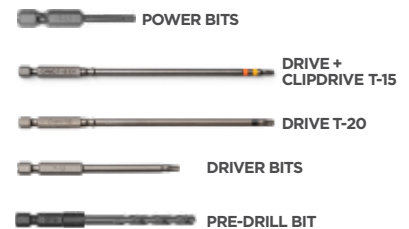

# FASTENERS FOR EVERY PROJECT

## SYSTEM FASTENERS

For exclusive use with CAMO® systems



CAMO EDGE SCREWS



CAMO COLLATED EDGE + FACE SCREWS

## CAMO UNIVERSAL DECK CLIPS



## EXTERIOR FASTENERS

For Deck, Composite, Trim, or Structural connections.

### BUGLEHEAD DECK



### COUNTERSINKING DECK



### COMPOSITE



### TRIM



How many fasteners does my deck project need?



Scan here for the CAMO Fastener Calculator.

## CODE-COMPLIANT STRUCTURAL SCREWS

IRC/IBC CODE-COMPLIANT



TRUSS



MULTI-PLY + LEDGER FLAT HEAD SCREWS



FRAMING SCREWS



MULTI-PURPOSE FLAT HEAD SCREWS



MULTI-PURPOSE HEX HEAD HDG SCREWS



MULTI-PURPOSE HEX HEAD SCREWS

## 316SS STAINLESS STEEL



305 & 316 COMPOSITE SCREWS



316 JOIST HANGER NAILS (COLLATED AVAILABLE)



305 & 316 DECK SCREWS



316 RING SHANK DECK NAILS (COLLATED AVAILABLE)



WEDGE 316SS



316 PAINTED TRIM SCREWS



305, 316 & 410 BLACK TRIM SCREWS



316 EDGE SCREWS

# CONTENTS

OVERVIEW	2
DRIVE SYSTEMS	4
CLIPDRIVE	4
UNIVERSAL DECK CLIPS	8
DRIVE	18
LEVER	26
MARKSMAN SYSTEM	32
DECK TAPE	38
BLOCK	40
EXTERIOR SCREWS + NAILS	44
STRUCTURAL	46
COATINGS	50
RESOURCES	52
SPECIAL CASES - EDGE	53
BEST PRACTICES - EDGE	55
INSTALLATION RECOMMENDATIONS BY BOARD TYPE	56
SPECIAL CASES - CLIP	60
TROUBLESHOOTING	62

CAMO products are user-friendly, intuitive, and designed to give you the best experience. To ensure you're confident in every install, we put together this comprehensive Training Guide.

We break down the components of CAMO tools, guide you on setting them up, and give you instructions for every install. We also included a resources section full of information about fastening in special cases, best practices, and troubleshooting.

Look through this Training Guide to get ready for your install, and you'll see why CAMO is the better way to build a deck.

# CLIPDRIVE™

Stand tall, target screws easily, and drive clips up to 5X faster with the CAMO® ClipDRIVE™, the contractor-grade tool designed to give you the best experience fastening grooved decking.

INTRODUCTION	5
SETUP	6
CLIPDRIVE USE	7

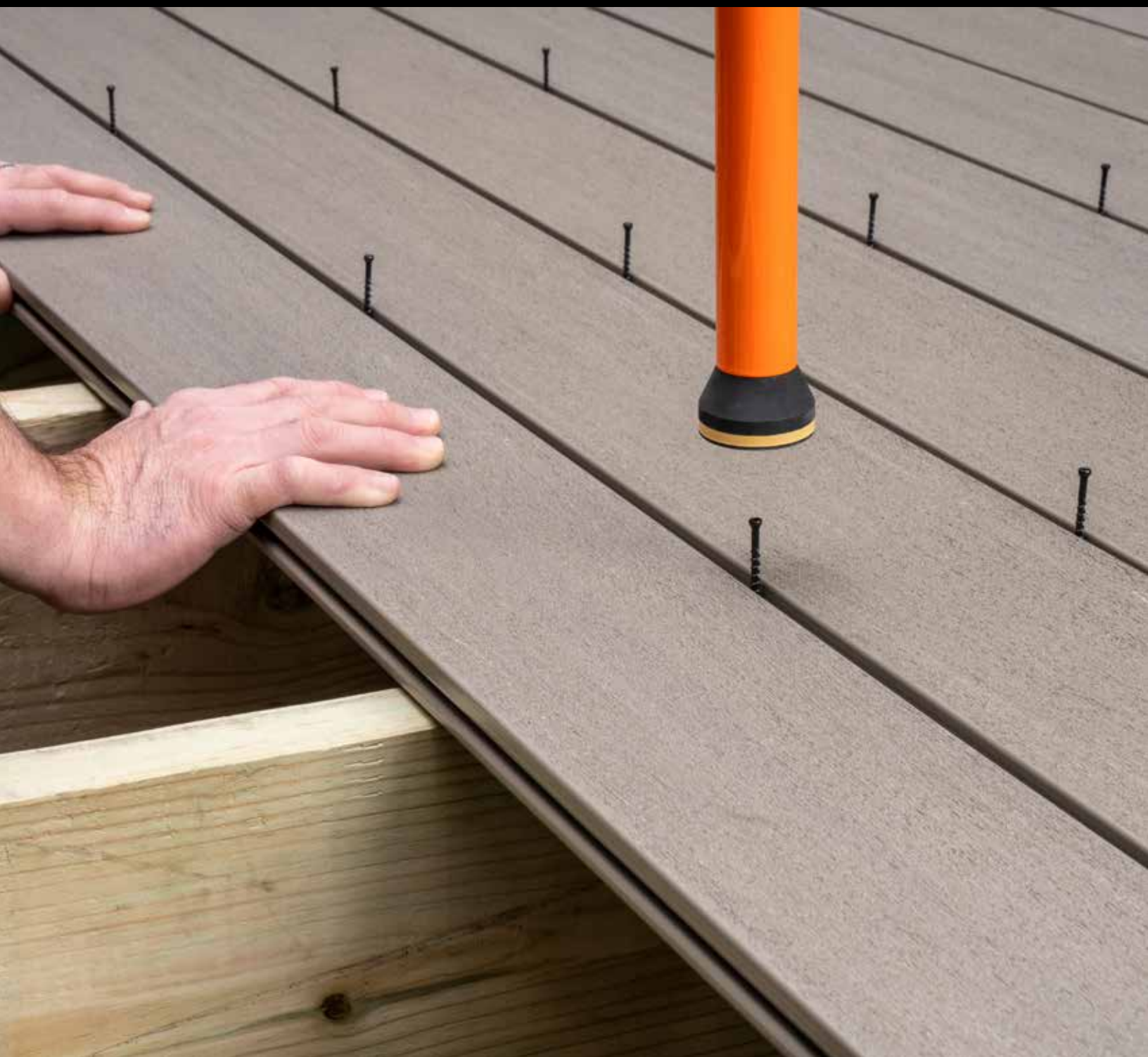



# Get to know your CLIPDRIVE tool



YOUR DRILL GOES HERE

COLLAR

DRIVE SHAFT

HEIGHT-ADJUSTABLE HANDLE

UPPER TOOL BODY

CHUCK (INSIDE COVER)

BIT HOLDER

LOWER TOOL BODY

T-15 DRIVER BIT

WEIGHTED NOSE

## FOR USE WITH CAMO UNIVERSAL DECK CLIPS



### FOR USE WITH CAMO CLIPS

(SOLD SEPARATELY)



90° DECK PATTERN  
WOOD JOISTS



ANY DECK PATTERN  
WOOD JOISTS



ANY DECK PATTERN  
METAL JOISTS



# Setup for Clip fastening



## A INSTALL T-15 DRIVER BIT



Separate the tool by turning the lower tool body counter-clockwise and sliding the locking pins out of the notches.



Pull back the collar, then insert the T-15 bit and release the collar to lock the bit in place.

## B CONNECT TOOL BODY



Align the notches in the lower tool body with the locking pins and push down while turning to lock into place.



Turn the lower tool body clockwise to lock it into place.

## C INSTALL THE HANDLE



Loosen the handle by turning it counter-clockwise and slide the clamp onto the tool.

Position the handle on the upper tool body and tighten by turning the handle clockwise.

## D ATTACH YOUR DRILL



Make sure the drill is set in the forward position. Insert the large collar of the drive shaft into the drill chuck and tighten.



If your drill has a drill and clutch mode, set it to clutch mode. Turn down torque to the lowest setting. Increase as necessary until the board is snugly fastened by the clip. Do not overdrive.



# How to Fasten with CLIPDRIVE



## BEFORE YOU BEGIN

Lay down rows of boards and clips and hold or lock them in place.



## 1 POSITION NOSE OVER CLIP\*

Starting at the outermost board, place the nose over the exposed screw.

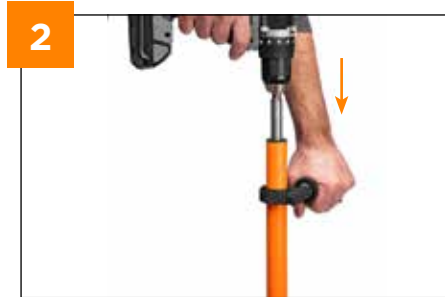

## 2 ENGAGE DRILL

With the nose flat on the surface of the board, and pressure on the handle, run the drill at full speed, and push the driver drill down to engage the bit and screw.



## 3 FASTEN THE BOARD

Apply steady pressure and continue to drive until the drill clutch releases or until clip is snug. **Do not overdrive.**



## 4 LIFT UP TOOL

After fastening, lift up on the tool to return your drill to starting position.

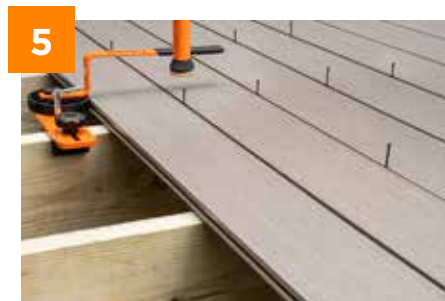

## 5 FASTEN EVERY JOIST

Fasten all of the remaining clips at each joist.

\*FIND MORE SPECIFIC INFORMATION ABOUT EACH CLIP TYPE ON PAGES 8-17.

# UNIVERSAL DECK CLIPS

CAMO Universal Deck Clips make installing grooved decking on wood and metal joists easy for everyone. These hidden deck clips are designed and warranted for use with leading grooved decking and result in a beautiful fastener-free surface that you can install in half the time of other hidden fasteners. Fasten EDGE®, WEDGECLIP™, and WEDGEMETAL® Clips by hand with the included NEVER-MISS® Guide, or, for the best experience, standing up with ClipDRIVE™ or DRIVE.

<b>INTRODUCTION</b>	<b>9</b>
<b>STARTER</b>	<b>10</b>
<b>EDGE</b>	<b>12</b>
<b>WEDGECLIP</b>	<b>14</b>
<b>WEDGEMETAL</b>	<b>16</b>





# Get to know your Clips

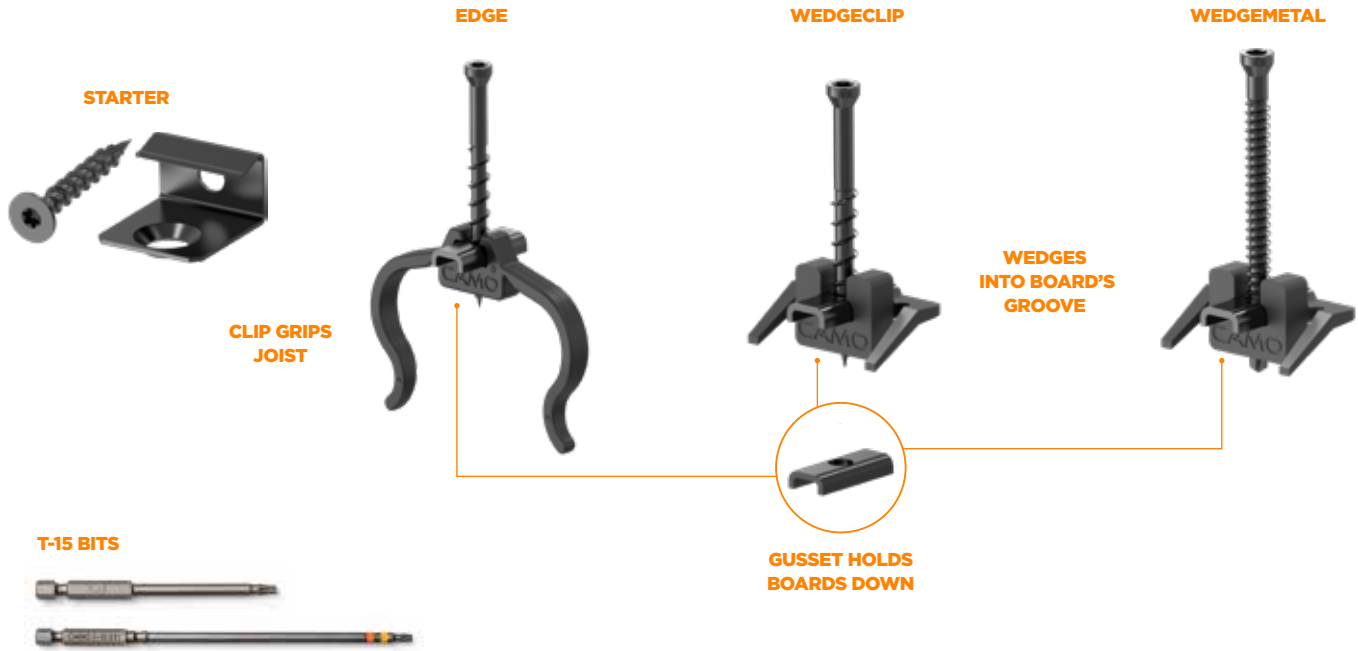

## WHICH CLIPS SHOULD I USE?

CLIP TYPE	90° PATTERNS	ANY PATTERN
	<b>STARTER CLIPS</b>	✓
<b>EDGE CLIPS</b>	✓	X
<b>WEDGECLIPS</b>	✓	✓
<b>WEDGEMETAL CLIPS</b>	✓	✓

GROOVED BOARD TYPE	
<b>COMPOSITE</b>	✓
<b>PVC</b>	✓
<b>CAPPED COMPOSITE</b>	✓
<b>HARDWOOD</b>	✓

Please reference our specific board installation instructions by board type on page 56

# Setup for STARTER Clips



## A INSERT T-15 BIT



Insert the T-15 driver bit into your drill. Do not use an impact driver.

## B ADJUST DRILL



If your drill has a drill and clutch mode, set it to clutch mode. Turn down torque to the lowest setting. Increase as necessary until the board is snugly fastened by the clip. Do not overdrive.



# How to fasten STARTER Clips



1



## FASTEN CLIP ON JOIST

Place clip on the joist, centered with the cross joist, and fasten.

2



## REPEAT

Install a STARTER Clip at every joist.

3



## PLACE BOARD

Tilt board up slightly to set it in the clips.

4



## LAY BOARD DOWN

Gently push the board down to lock it in place.

# Setup for EDGE Clips



## A INSERT T-15 BIT



Insert the T-15 driver bit into your drill.  
Do not use an impact driver.

## B ADJUST DRILL



If your drill has a drill and clutch mode, set it to clutch mode. Turn down torque to the lowest setting. Increase as necessary until the board is snugly fastened by the clip. Do not overdrive.



# How to fasten EDGE Clips



## BEFORE YOU BEGIN

Fasten your first board with CAMO STARTER Clips (p. 11).



SCAN TO  
WATCH THE  
HOW-TO  
VIDEO

1



## PLACE CLIP ON JOIST

Place a clip on the joist with the gusset in the groove. Clips stay in place until you're ready to fasten.

2



## REPEAT ALONG THE BOARD

Place a clip at every joist along the length of the board.

3



## SLIDE ON NEXT BOARD

Place the next board up against the clips, and repeat until you have multiple rows of boards and clips.

4



## LOCK-IN YOUR BOARDS

Hold the boards tightly, or lock them in place with CAMO LEVER® (sold separately).



5



## FASTEN WITH NEVER-MISS® GUIDE

Starting at the outermost board, place the NEVER-MISS Guide (included IN 450 ct and 900 ct) over the screw head, connect the bit to the head and drive until clip is snug. **Do not overdrive.** Repeat until all inner boards are fastened.



## OR FASTEN WITH CLIPDRIVE™ (OPTIONAL)

To fasten with ClipDRIVE, starting at the outermost board, put the nose over the screw head and drive at full RPM while applying downward pressure. Repeat until all inner boards are fastened. See full instructions on page 7.

# Setup for WEDGECLIPS



## A INSERT T-15 BIT



Insert the T-15 driver bit into your drill. Do not use an impact driver.

## B ADJUST DRILL



If your drill has a drill and clutch mode, set it to clutch mode. Turn down torque to the lowest setting. Increase as necessary until the board is snugly fastened by the clip. Do not overdrive.

# How to fasten WEDGECLIPS



## BEFORE YOU BEGIN

Fasten your first board with CAMO STARTER Clips (p. 11).



SCAN TO WATCH THE HOW-TO VIDEO



## 1 WEDGE INTO GROOVE

Tilt the WEDGECLIP so the lower prongs enter the groove first. Tilt the clip back up to wedge into the groove. Clips stay in place until you're ready to fasten.



## 2 REPEAT ALONG THE BOARD

Place a clip at every joist along the length of the board.



## 3 SLIDE ON NEXT BOARD

Place the next board up against the clips, and repeat until you have multiple rows of boards and clips.



## 4 LOCK-IN YOUR BOARDS

Hold the boards tightly, or lock them in place with CAMO LEVER® (sold separately).



## 5 FASTEN WITH NEVER-MISS® GUIDE

Starting at the outermost board, place the NEVER-MISS Guide (included in 450 and 900 ct) over the screw head, connect the bit to the head and drive until clip is snug. **Do not overdrive.** Repeat until all inner boards are fastened.



## OR FASTEN WITH CLIPDRIVE™ (OPTIONAL)

To fasten with ClipDRIVE, starting at the outermost board, put the nose over the screw head and drive at full RPM while applying downward pressure. Repeat until all inner boards are fastened. See full instructions on pages 7.



# Setup for WEDGEMETAL Clips



## A INSERT T-15 BIT



Insert the T-15 driver bit into your drill.  
Do not use an impact driver.

## B ADJUST DRILL



If your drill has a drill and clutch mode, set it to clutch mode. Turn down torque to the lowest setting. Increase as necessary until the board is snugly fastened by the clip. Do not overdrive.

# How to fasten WEDGEMETAL Clips



SCAN TO  
WATCH THE  
HOW-TO  
VIDEO

1



## WEDGE INTO GROOVE

Tilt the WEDGEMETAL Clip so the lower prongs enter the groove first. Tilt the clip backup to wedge into the groove. Clips stay in place until you're ready to fasten.

2



## REPEAT ALONG THE BOARD

Place a clip at every joist along the length of the board.

3



## SLIDE ON NEXT BOARD

Place the next board up against the clips, and repeat until you have multiple rows of boards and clips.

4



## LOCK-IN YOUR BOARDS

Hold the boards tightly, or lock them in place with CAMO LEVER® (sold separately).



5



## FASTEN WITH NEVER-MISS® GUIDE

Starting at the outermost board, place the NEVER-MISS Guide (included in 450 ct AND 900 ct) over the screw head, connect the bit to the head and drive. Repeat until all inner boards are fastened.



## OR FASTEN WITH CLIPDRIVE™ (OPTIONAL)

To fasten with ClipDRIVE, starting at the outermost board, put the nose over the screw head and drive at full RPM while applying downward pressure. Repeat until all inner boards are fastened. See full instructions on pages 7.



# DRIVE

Stand up, save your back and knees, and save your time with the award-winning CAMO DRIVE® system. The DRIVE tool can be used to fasten almost any board\* while comfortably standing up. DRIVE is for exclusive use with CAMO Collated Edge and Face Screws and CAMO Universal Deck Clips.

<b>INTRODUCTION</b>	<b>19</b>
<b>DRIVE FOR EDGE FASTENING</b>	<b>20</b>
<b>DRIVE FOR FACE FASTENING</b>	<b>22</b>
<b>DRIVE FOR CLIP FASTENING</b>	<b>24</b>

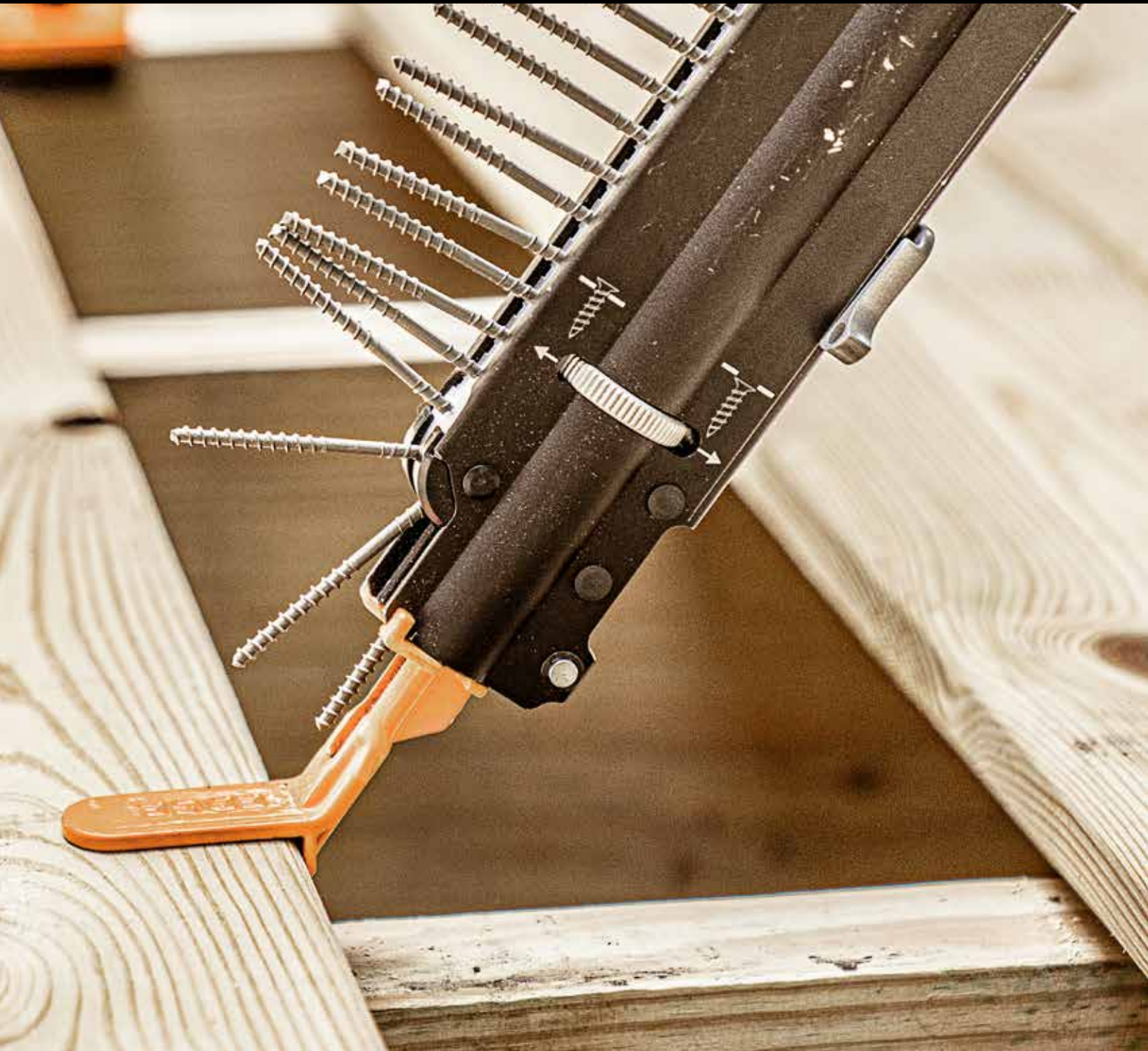



# Get to know your *DRIVE* tool

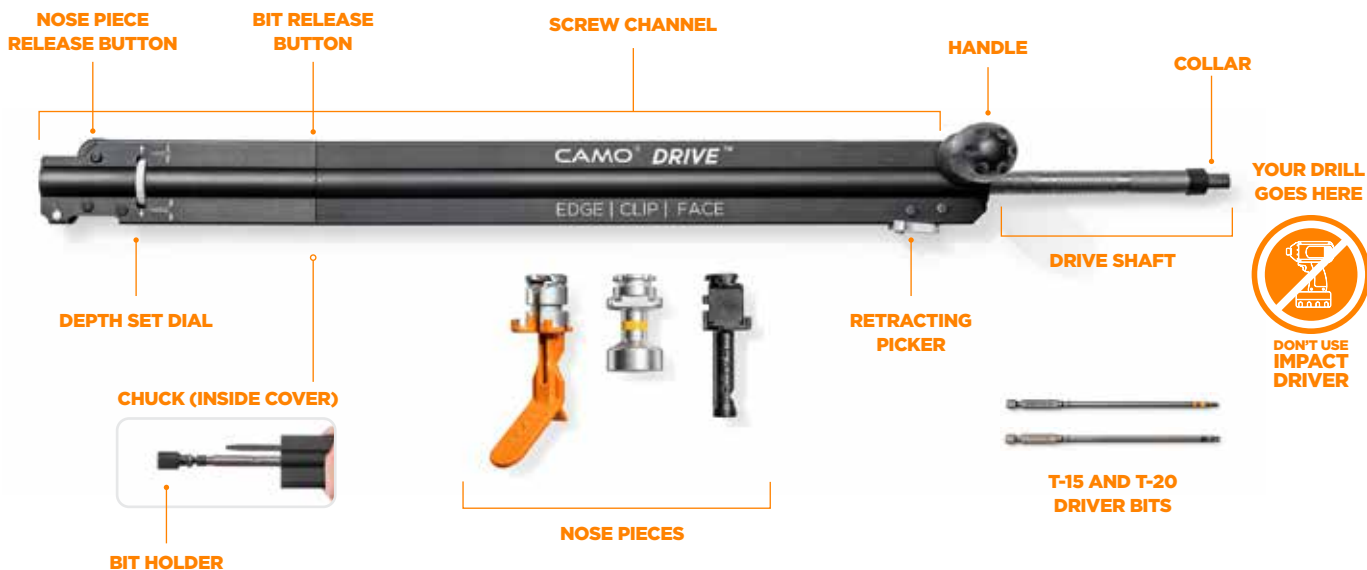

## SELECT A NOSE PIECE

	EDGE	CLIP	FACE
Nose Piece			
How It Works			
Compatible Board Profiles	Square Edge	Grooved	Square Edge
Compatible Deck Boards	Pressure Treated Composite PVC Cedar Redwood	Composite PVC Capped Composite* Hardwood*	Pressure Treated Composite PVC Capped Composite*
Compatible Fasteners	Collated Edge Screws	Universal Deck Clips	Collated Wood and Composite Screws

## FOR EXCLUSIVE USE WITH CAMO COLLATED SCREWS



## FOR EXCLUSIVE USE WITH CAMO UNIVERSAL DECK CLIPS



\*We do not recommend using the DRIVE tool to Edge fasten capped composites or hardwood as these boards need to be pre-drilled. Instead, use the MARKSMAN Pro® Tool and Edge Screws (p. 32).

# Setup for Edge fastening



## A INSTALL T-15 DRIVER BIT



Using a bit, press the release button in the channel and remove the lower body of the tool.



Position the tool body so the large collar of the drive shaft is on a stable surface.



Pull the body of the tool back with one hand to reveal the bit holder. Continue to hold in place.



Put the T-15 bit in your other hand, pull down on the bit holder, and set the bit in place.



Pull up on the bit holder to ensure the bit is locked in.



Slide the lower tool body over the bit—it will click into position.

## B INSERT EDGE NOSE PIECE



Press the release button.



Insert the Edge nose piece. It will lock into place.

## C INSTALL HANDLE



Attach the handle by screwing it onto the bolt at the top of the tool. You can reverse the handle for right or left-handed use by simply loosening the bolt and reinstalling it on the other side of the tool.

## D ATTACH YOUR DRILL



Make sure the drill is set in the forward position. Insert the large collar of the drive shaft into the drill chuck and tighten.



Set your drill to its highest torque setting.

## E INSERT SCREW STRIP



Slide the collated screw strip into the screw strip channel.



Push the strip through the nose piece.



Slide the picker up.



Push the end of the strip into the picker teeth.

## F TEST & ADJUST SCREW HEIGHT



Before fastening on the deck top, drive a few screws into a scrap piece of material and adjust the depth set dial accordingly. For Edge screws, sink them 1/8-1/4 in below the surface of the deck board.

# How to Edge fasten

## BEFORE YOU BEGIN

Where Edge fastening with the DRIVE isn't possible, use CAMO Premium Deck or Composite Screws. Go to page 53 for full instructions.



SCAN TO WATCH THE HOW-TO VIDEO



## POSITION NOSE PIECE

Starting on the outer edge of the board, line up the nose piece with the joist at least 1 in from the board end.



## ENGAGE DRILL

With the nose piece flat on the surface of the board, and pressure on the DRIVE handle, run the drill at full speed, and push the driver drill down to engage the bit and screw.



## FASTEN THE BOARD

Apply steady pressure, but do not force the screw—it will auger the surface on its own. Continue driving until the drill is fully compressed and the depth release disengages.



## LIFT DRIVE UP

After fastening, lift up on the DRIVE tool to return your drill to starting position. The screw will automatically advance.



## FASTEN EVERY JOIST

Install a screw at every joist on the outer edge of the board.



## REPEAT ON OTHER SIDE OF THE BOARD

Follow the same steps to fasten the inside edge of the board.



# Setup for Face fastening



## A INSTALL T-20 DRIVER BIT



Using a bit, press the release button in the channel and remove the lower body of the tool.



Position the tool body so the large collar of the drive shaft is on a stable surface.



Pull the body of the tool back with one hand to reveal the bit holder. Continue to hold in place.



Put the T-20 bit in your other hand, pull down on the bit holder, and set the bit in place.



Pull up on the bit holder to fully insert the bit and then pull up on the bit to make sure it is locked in place.



Slide the lower tool body over the bit—it will click into position.

## B INSERT EDGE NOSE PIECE



Press the release button.



Insert the Face nose piece. It will lock into place.

## C INSTALL HANDLE



Attach the handle by screwing it onto the bolt at the top of the tool. You can reverse the handle for right or left-handed use by simply loosening the bolt and reinstalling it on the other side of the tool.

## D ATTACH YOUR DRILL



Make sure the drill is set in the forward position. Insert the large collar of the drive shaft into the drill chuck and tighten.



Set your drill to its highest torque setting.

## E INSERT SCREW STRIP



Slide the collated screw strip into the screw strip channel.



Push the strip through the nose piece.



Slide the picker up.



Push the end of the strip into the picker teeth.

## F TEST & ADJUST SCREW HEIGHT



Before fastening on the deck top, drive a few screws into a scrap piece of material and adjust the depth set dial accordingly. For Face screws, you can drive them flush or countersink them.

# How to Face fasten



SCAN TO  
WATCH THE  
HOW-TO  
VIDEO

1



## POSITION NOSE PIECE

Starting on the outer edge of the board, line up the nose piece with the joist at least 1 in from the board end and edge.

2



## ENGAGE DRILL

With the nose piece flat on the surface of the board, and pressure on the DRIVE handle, run the drill at full speed, and push the driver drill down to engage the bit and screw.

3



## FASTEN THE BOARD

Apply steady pressure, but do not force the screw—it will auger the surface on its own. Continue driving until the drill is fully compressed and the depth release disengages.

4



## LIFT DRIVE UP

After fastening, lift up on the DRIVE tool to return your drill to starting position. The screw will automatically advance.

5



## FASTEN EVERY JOIST

Install two screws at every joist until the entire board is installed.

# Setup for Clip fastening

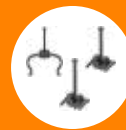

## A INSTALL T-15 DRIVER BIT



Using a bit, press the release button in the channel and remove the lower body of the tool.



Position the tool body so the large collar of the drive shaft is on a stable surface.



Pull the body of the tool back with one hand to reveal the bit holder. Continue to hold in place.



Put the T-15 bit in your other hand, pull down on the bit holder, and set the bit in place.



Pull up on the bit holder to ensure the bit is locked in.



Slide the lower tool body over the bit—it will click into position.

## B INSERT CLIP NOSE PIECE



Press the release button.



Insert the Clip nose piece. It will lock into place.

## C INSTALL HANDLE



Attach the handle by screwing it onto the bolt at the top of the tool. You can reverse the handle for right or left-handed use by simply loosening the bolt and reinstalling it on the other side of the tool.

## D ATTACH YOUR DRILL



Make sure the drill is set in the forward position. Insert the large collar of the drive shaft into the drill chuck and tighten.



If your drill has a drill and clutch mode, set it to clutch mode. Turn down torque to the lowest setting. Increase as necessary until the board is snugly fastened by the clip. **Do not overdrive.**



# How to Clip fasten



## BEFORE YOU BEGIN

Lay down rows of boards and clips\* and hold or lock them in place.



SCAN TO  
WATCH THE  
HOW-TO  
VIDEO

1



## POSITION NOSE PIECE

Starting at the outermost board, place the Clip\* nose piece over the exposed screw.

2

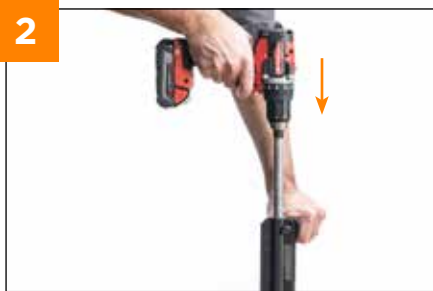

## ENGAGE DRILL

With the nose piece flat on the surface of the board, and pressure on the DRIVE handle, run the drill at full speed, and push the driver drill down to engage the bit and screw.

3



## FASTEN THE BOARD

Apply steady pressure and continue to drive until the drill clutch releases or until clip is snug. **Do not overdrive.**

4



## LIFT DRIVE UP

After fastening, lift up on the DRIVE tool to return your drill to starting position.

5



## FASTEN EVERY JOIST

Fasten all of the remaining clips at each joist.

\*FIND MORE SPECIFIC INFORMATION ABOUT EACH CLIP TYPE ON PAGES 8-17.



# LEVER

Build a better deck by yourself with LEVER, the one-turn tool that locks-in rows of boards and clips and straightens warped boards.

INTRODUCTION	27
BENDING	28
LOCKING	30



# Get to know your *LEVER* tool



## ASSEMBLING YOUR TOOL

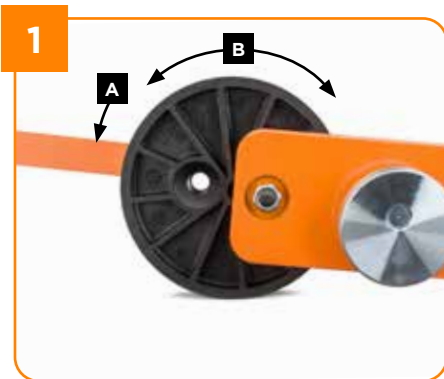

### ALIGN

A) Straighten the handle.  
B) Align the holes in the handle and cam by rotating the cam.



### INSERT SCREW

Insert flathead screw from the bottom of board cam.



### TIGHTEN

Use supplied hex key to securely tighten the screw.



# Setup for bending warped boards

## A SET THE JOIST TYPE—WOOD OR METAL



Loosen joist knob until the stop block disengages.



Rotate the stop block to the desired side, align the block with the holes, push back into place, and tighten the joist knob.

## B SET THE JOIST WIDTH



Adjust the stop block to the proper joist width and tighten the knob.



The Single Joist setting accommodates joists 1-½ in wide. The Double Joist setting accommodates joists 3 in wide.

# How to bend warped boards



## 1 SECURE BOARD

Get your board in place and fasten one end.



## 2 POSITION

Place LEVER on the joist at the opposite end of the board and tighten the joist cam with the pivot pin



## 3 BEGIN BENDING

Apply pressure by moving the handle towards the deck board.



## 4 CLOSE THE GAP

Keep turning until the board is in desired fastening position.



## 5 FASTEN

Fasten the board.

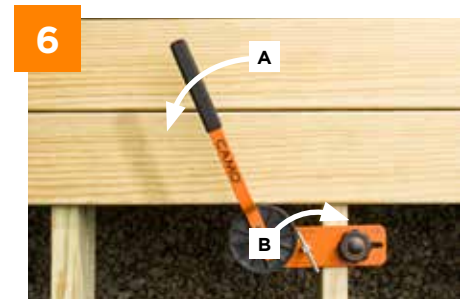

## 6 RELEASE & REMOVE

A) Release pressure by moving the handle away from the deck board.  
B) Loosen the joist cam and remove LEVER.

# Setup for locking boards and Clips

## A SET THE JOIST TYPE—WOOD OR METAL



Loosen joist knob until the stop block disengages.



Rotate the stop block to the desired side, align the block with the holes, push back into place, and tighten the joist knob.

## B SET THE JOIST WIDTH



Adjust the stop block to the proper joist width and tighten the knob.



The Single Joist setting accommodates joists 1-1/2 in wide. The Double Joist setting accommodates joists 3 in wide.



# How to lock boards

For the best experience with consistent board spacing, use 2-4 LEVER tools across the length of the deck.



## 1 PREPARE BOARDS

Lay down multiple rows of boards and CAMO Universal Deck Clips.



## 2 POSITION

Place LEVER on the joist and tighten the joist cam with the pivot pin.



## 3 LOCK-IN

Apply pressure by moving the handle towards the deck board. Do not over-tighten as the boards can buckle.



## 4 FASTEN

Leave LEVER in place until all clips are fastened.



## 5 RELEASE

Release pressure by moving the handle away from the deck board.



## 6 REMOVE

Loosen the joist cam and remove LEVER.



# MARKSMAN®

Achieve a fastener-free surface on square edge decking with this easy and affordable hidden fastening system. MARKSMAN Tools automatically establish spacing between boards and direct CAMO Edge Screws into the edge of the board, leaving a smooth deck surface. Plus, the MARKSMAN system is backed by a CAMO warranty for use in leading deck boards.

INTRODUCTION	33
MARKSMAN PRO TOOLS	34
MARKSMAN EDGE	36



# Get to know your MARKSMAN tools

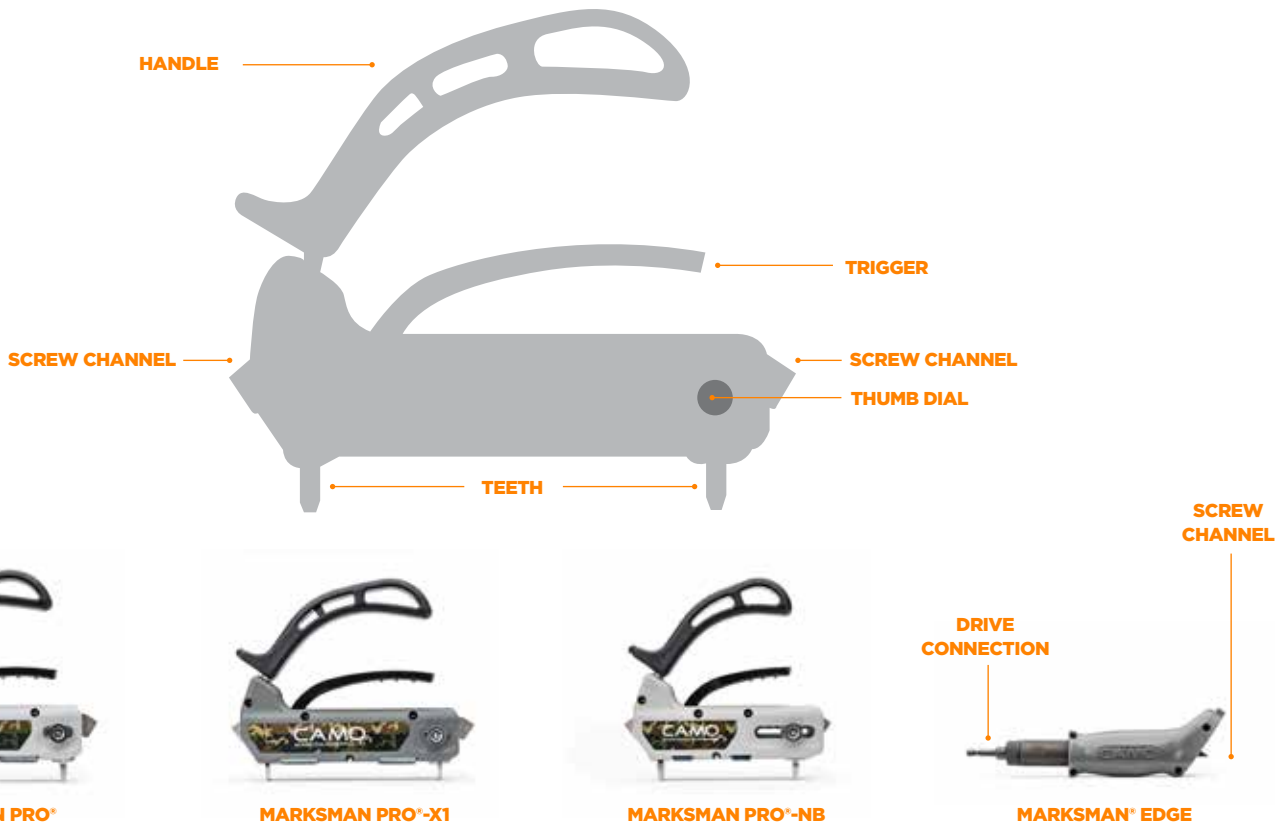

## FOR USE WITH CAMO EDGE SCREWS

### PROTECH COATED



### STAINLESS STEEL



## WHICH TOOL SHOULD I USE?

	MARKSMAN PRO	MARKSMAN PRO-X1	MARKSMAN PRO-NB	MARKSMAN EDGE
Tool				
Gap	3/16 in	1/16 in	3/16 in	None
Board Width	5-1/4 to 5-3/4 in	5-1/4 to 5-3/4 in	3-1/4 to 5 in	Any
Compatible Boards	KDAT Composite PVC Capped Composite (with pre-drilling) Cedar Redwood Hardwood (with pre-drilling)	Pressure Treated	KDAT Composite PVC Capped Composite (with pre-drilling) Cedar Redwood Hardwood (with pre-drilling)	Pressure Treated



# Setup for MARKSMAN Pro Tools



## A INSERT T-15 BIT



Insert the T-15 driver bit into your drill. Do not use an impact driver.

## B IF YOU'RE PRE-DRILLING\*, INSERT THE PRE-DRILL BIT



Speed up the job by attaching the pre-drill bit to another drill.\*

## C ADJUST DRILL



Adjust drill to the highest speed setting and highest torque.

## D ADJUST SPACER TEETH



Adjust the spacer teeth on the tool with the thumb dial to fit your board.

\*Partial pre-drilling is required for capped composite and hardwoods.

# How to fasten Edge Screws

## BEFORE YOU BEGIN

Ensure you're using the proper spacing for your deck boards. We recommend 1/16" board gap for pressure treated lumber, and 3/16" board gap with composite and PVC. Where Edge fastening with the MARKSMAN Pro Tools isn't possible, use CAMO Premium Deck or Composite Screws. Go to page 54 for full instructions.



SCAN TO  
WATCH THE  
HOW-TO  
VIDEO

1



## PLACE TOOL

Place the tool on the board so it's in line with the joist. If you are NOT pre-drilling, skip to step 3.

2



## DRILL HOLE\*

If pre-drilling, run the pre-drill bit through both screw channels\*.

**\*Partial pre-drilling is required for capped composite and hardwoods.**

3



## LOAD SCREWS

Load an Edge screw into both screw channels.

4



## DRIVE

Drive the screw in on both sides letting the screw do the work. The shoulder on the bit will stop the screw from overdriving.

# Setup for MARKSMAN EDGE



## A ATTACH YOUR DRILL



Attach the Drive Connection to your drill.

**NOTE:** The MARKSMAN EDGE tool leaves no gap between boards. If you desire a gap, place secondary spacers before fastening.



# How to fasten Edge screws

## BEFORE YOU BEGIN

Where Edge fastening with the MARKSMAN EDGE isn't possible, use CAMO Premium Deck or Composite Screws. Go to page 54 for full instructions.

1



### LOAD A SCREW

Load an Edge screw into the magnetized screw channel.

2



### PLACE TOOL ON BOARD

Align the screw channel with the joist, ensuring the face of the tool is flat. Tooth should be on the edge of the board.

3



### DRIVE

Drive the screw until it's fully seated in the board.

# JOIST + LEDGER DECK TAPE

CAMO Joist + Ledger Deck Tape is a self-adhering protective membrane engineered to protect decks from premature rot and corrosion. It features a high-performance butyl hybrid adhesive with a high-strength non-slip polypropylene backing. CAMO Deck Tape will self-seal around nails and fasteners to prevent water infiltration, wood rot and lumber breakdown. Product comes individually wrapped in labeled rolls.

APPLICATION & INSTALLATION

39

## AVAILABLE IN 3 SIZES



# Applications for Deck Tape

**A** BETWEEN JOIST HANGERS AND LEDGER BOARD



**B** BETWEEN FRAMING AND JOIST HANGERS



**C** LEDGER BOARD



**D** TOP OF JOISTS



**E** TOP OF DOUBLE JOISTS



**F** BETWEEN RIM JOISTS AND FASCIA



## How to install Deck Tape

### INSTALLATION INSTRUCTIONS

Surfaces should be clean and dry.

Best when applied in temperatures above 20° F (-6.7°C).



**1** PEEL BACK THE RELEASE PAPER



**2** APPLY TO THE INTENDED SURFACE AND PRESS INTO PLACE



**3** CUT TAPE TO THE DESIRED LENGTH



# BLOCK

Build a better freestanding deck from the ground up. If you're building a freestanding Deck 5½ in to 30 in tall, there's no better solution than CAMO BLOCK®.

INTRODUCTION 41

INSTALLATION 42



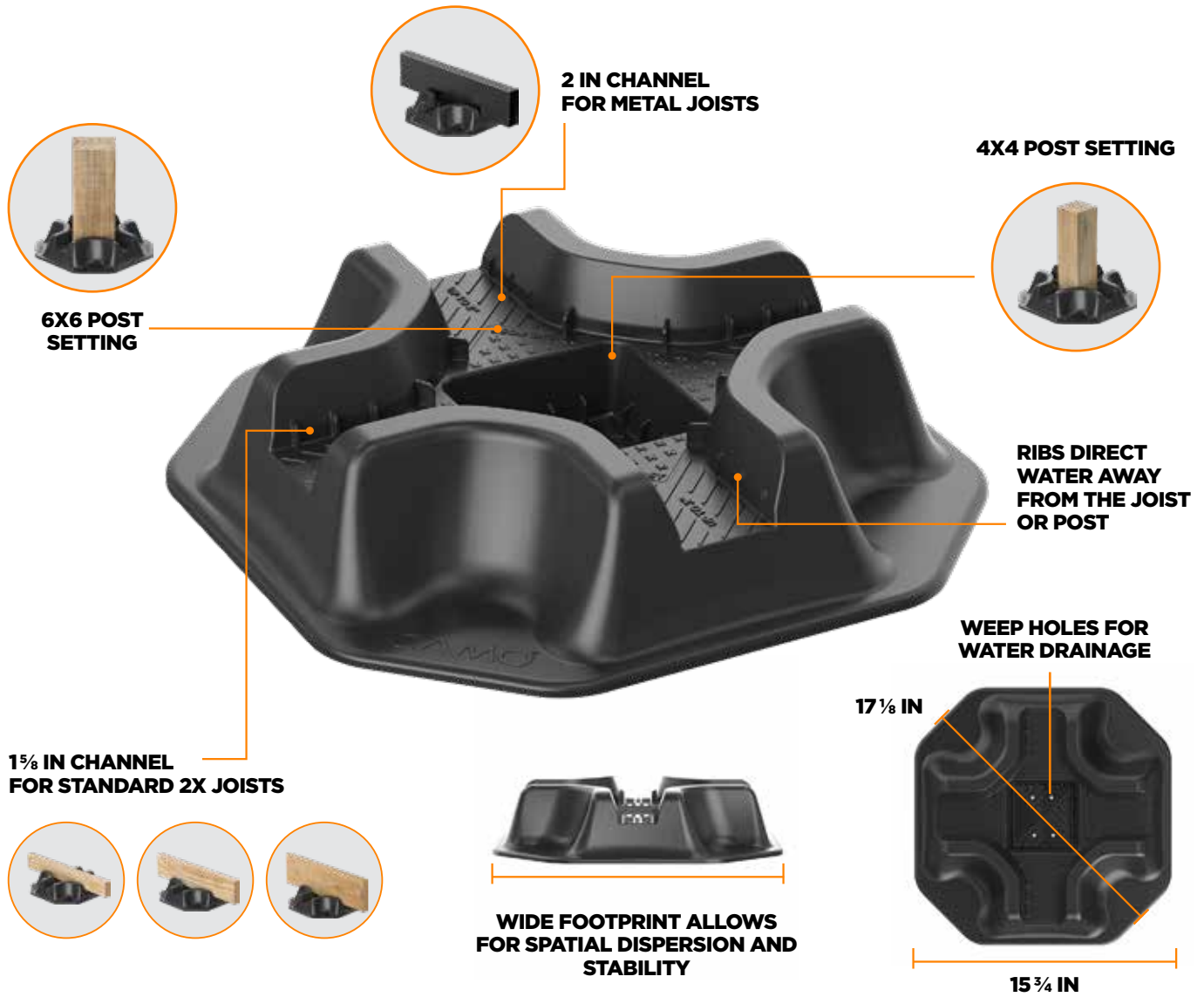

## USE BLOCK FOR VARIOUS PROJECTS

LOW-PROFILE + ROOFTOP DECKS



VARIABLE - HEIGHT DECKS



RAISED DECKS



INTERMEDIARY FOOTINGS



LANDINGS



SHEDS



DOG HOUSES

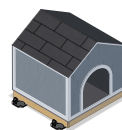

WALKWAYS



# Installation Considerations for *BLOCK*



## A QUICK INSTALLATION

*If you're in a dry environment with level ground, you can opt to not use paver base and follow the steps below.*



Remove grass and loose soil and place BLOCK on level, undisturbed ground.

## A INSTALLING ON UNEVEN SURFACES

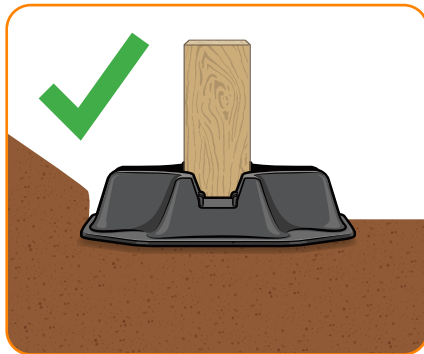

If you're building on an uneven surface, you will need to dig out the ground to ensure BLOCK is sitting on a level surface.

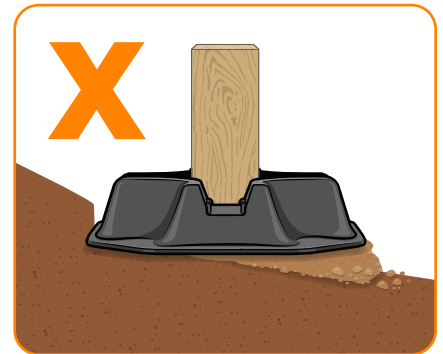
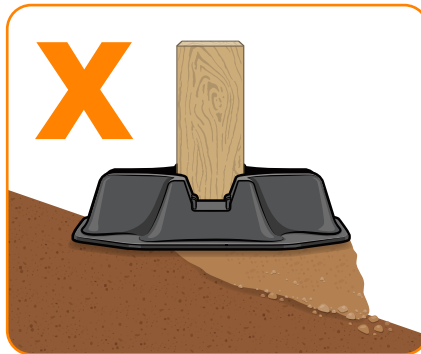

**Never build up the footing beneath the BLOCK.**



# How to install **BLOCK**

## BEST PRACTICE INSTALLATION

To build a strong foundation for your project that will last, follow the steps below



FOR MORE IN-DEPTH BLOCK INSTALLATION INSTRUCTIONS BY DECK TYPE, PLEASE REFERENCE THE BLOCK INSTALLATION GUIDE.

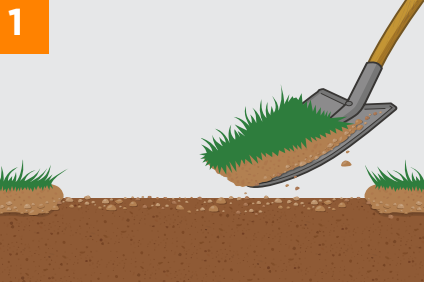

### 1 REMOVE SOIL

Remove at least 2 in of top soil.

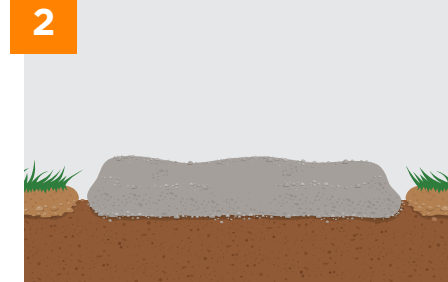

### 2 CREATE BASE

Fill with 3 in of paver base material

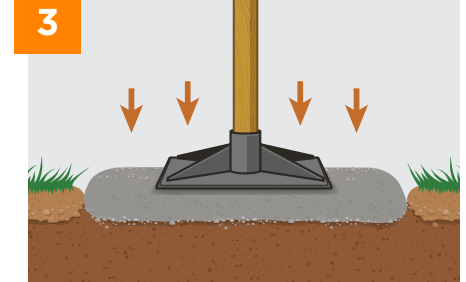

### 3 LEVEL BASE

Compact the paver base until level

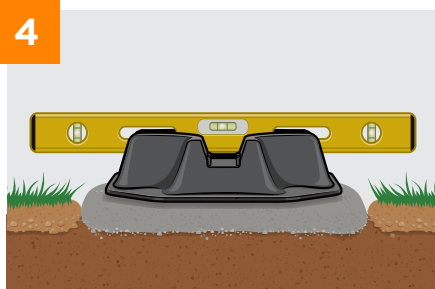

### 4 PLACE BLOCK

Place BLOCK, check that it's level, and adjust as necessary

## Deck Heights

You can use BLOCK to build deck substructures 5½ in to 30 in tall. **Always check with your local building code officials before starting any project.**

Freestanding decks 30 in tall or less, and smaller than 200 square feet in size, typically do not require building permits.

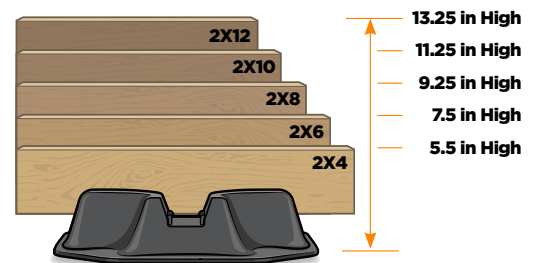

*For final deck height, take into account the thickness of your deck boards as well.*

# EXTERIOR SCREWS + NAILS

CAMO offers a high-quality line of exterior screws + nails that deliver on reliability no matter the project. CAMO Deck, Composite, and Trim Screws are available in our proprietary PROTECH® coating. Our code-compliant Structural Screws feature our industry-leading PROTECH Ultra 4 coating. We also carry a line of 305 Stainless Steel and 316 Stainless Steel for cedar, redwood, and hardwoods, and agricultural and coastal applications where you need more corrosion resistance. We back our exterior screws + nails with a CAMO warranty against rust and corrosion so you can confidently use them in all of your decking projects, substructures, landscaping, fences, pole barns, and more.

<b>INTRODUCTION</b>	<b>45</b>
<b>STRUCTURAL</b>	<b>46</b>
<b>COATINGS</b>	<b>50</b>



## WHICH FASTENER SHOULD I USE?

### RECOMMENDED APPLICATIONS FOR EACH FASTENER TYPE

 <b>EDGE SCREWS</b>	 <b>DECK SCREWS</b>	 <b>COMPOSITE SCREWS</b>	 <b>TRIM SCREWS</b>	 <b>STRUCTURAL SCREWS*</b>	 <b>HAND DRIVE NAILS</b>	 <b>COLLATED NAILS</b>
<ul style="list-style-type: none"> <li>• Edge with MARKSMAN Pro® Tools</li> <li>• Square edge decking projects where a hidden fastener finish is desired</li> </ul>	<ul style="list-style-type: none"> <li>• Wood decking projects</li> <li>• Fences</li> <li>• Any exterior wood-to-wood connection</li> </ul>	<ul style="list-style-type: none"> <li>• Composite decking projects</li> <li>• PVC decking projects</li> </ul>	<ul style="list-style-type: none"> <li>• Wood and PVC decking</li> <li>• Exterior trim</li> <li>• Deck rails</li> <li>• Balusters</li> <li>• Fences</li> </ul>	<ul style="list-style-type: none"> <li>• Framing</li> <li>• Truss</li> <li>• Ledger</li> <li>• Multi-Ply</li> <li>• Multi-Purpose</li> </ul>	<ul style="list-style-type: none"> <li>• Wood decking</li> <li>• Wood patios</li> <li>• Wood-to-wood connections</li> <li>• Joist hangers</li> </ul>	<ul style="list-style-type: none"> <li>• Framing</li> <li>• General construction</li> <li>• Decks and fences</li> <li>• Metal joist hangers</li> </ul>

\*CODE-COMPLIANT



# Get to know your Exterior Screws + Nails

## SCREWS

## NAILS

**BUGLE HEAD DECK**    **COUNTER SINKING DECK**    **COMPOSITE**    **TRIM**    **CODE-COMPLIANT STRUCTURAL**

**STAR DRIVE FOR BEST CONNECTIONS**

**PROTECH® + STAINLESS STEEL**    **PROTECH®**    **PROTECH® + STAINLESS STEEL**    **PROTECH® + STAINLESS STEEL**    **PROTECH® + PROTECH® ULTRA 4 + HOT DIP GALVANIZED**

**SCREW TIPS START FAST**

**RING SHANK DECK**    **COLLATED RING SHANK FRAMING**    **JOIST HANGER**    **COLLATED METAL HANGER**

**RING SHANK HOLDS STRONG**    **SMOOTH SHANK DRIVES FAST**

**316 STAINLESS STEEL**

**21° PLASTIC STRIP FITS MOST 20°-22° FRAMING NAILERS**    **STRIP FITS MOST 31° METAL CONNECTOR NAILERS**

FOR EXCLUSIVE USE WITH CAMO DRIVE® SYSTEM

## COLLATED SCREWS

FOR EXCLUSIVE USE WITH MARKSMAN SYSTEM

## EDGE SCREWS

**WOOD FACE**    **EDGE**    **COMPOSITE**

**STAR DRIVE FOR BEST CONNECTIONS**

**PROTECH®**    **PROTECH® + STAINLESS STEEL**

**RAKE TIP AUGERS OUT MATERIALS**    **SCREW TIPS START FAST**

**STAR DRIVE FOR BEST CONNECTIONS**

**PROTECH®**    **316 STAINLESS STEEL**

**RAKE TIP AUGERS OUT MATERIALS**

CAMO Exterior Fasteners can also be used for interior applications



# CAMO STRUCTURAL SCREWS

CAMO offers a full line of high-performing, code-compliant structural screws for all your deck, framing, and general construction needs. They are engineered to start fast, drive smooth, and hold strong. No pre-drilling required.

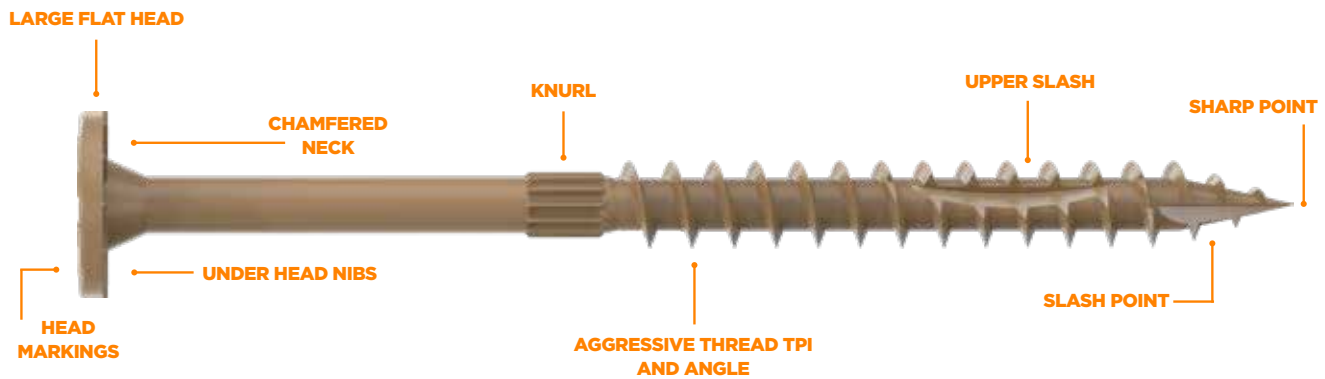

## THIRD PARTY TESTED. CODE COMPLIANT. DRJ CERTIFIED.

Our structural screws have been independently tested, audited and certified as IBC and IRC code-compliant by DrJ Engineering, an accredited certification body. Our screws have received technical evaluation reports from DrJ certifying code compliance for general screw properties and specific structural applications.



## INDUSTRY-LEADING SUPERIOR COATING.

When it comes to protecting your connections, we don't skimp. Our PROTECH Ultra 4 coating system features four layers that combine to provide the ultimate protection against harsh environmental elements. We test our coating 2X longer than industry standard, so you can be confident your connections will last. We offer a line of hot-dip galvanized hex head screws for coastal applications.

## PROTECH® ULTRA 4 COATING

- BLACK
- TAN



# FRAMING SCREWS



Don't trust your framing to nails or deck screws - use code-compliant CAMO Framing Screws for better holding power and stronger connections. These screws are specifically designed and load-rated for interior and exterior framing applications.

**SIZES:**

2½ in

(63.5mm)

3 in

(76.2mm)

**FEATURES:**

- PROTECH® Ultra 4 Coating
- Code listed per DrJ TER No. 2102-01 and State of Florida FL 41741
- Replaces 8d, 10d, and 16d nails in interior and exterior applications
- For Wood-to-wood framing, cabinets, gardening and landscaping projects, and general construction applications



WOOD-TO-WOOD FRAMING



DECK BLOCKING



INTERIOR PROJECTS



GENERAL CONSTRUCTION

# MULTI-PURPOSE FLAT HEAD SCREWS



Skip pre-drilling and enjoy fast starts with CAMO Flat Head Multi-Purpose Screws. These code-compliant screws replace traditional lag screws and through-bolts in projects like deck posts, beams, and other general construction projects. 1/4" and 5/16" screws available in a variety of lengths for you to conquer any project.

**SIZES:**

1/4 in Diameter Lengths:

3 in

(76.2mm)

4 in

(101.6mm)

6 in

(152.4mm)

8 in

(203.2mm)

10 in

(254mm)

5/16 in Diameter Lengths:

8 in

(203.2mm)

10 in

(254mm)

**FEATURES:**

- PROTECH® Ultra 4 Coating
- Code listed per DrJ TER No. 2102-01 and State of Florida FL 41741
- Replaces traditional lag screws and through-bolts
- For deck blocking, deck posts, beams, and railings, gardening and landscaping projects, and general construction applications



GARDENING + LANDSCAPING PROJECTS



DECK POSTS, BEAMS + RAILINGS



GENERAL CONSTRUCTION



DECK BLOCKING

# MULTI-PURPOSE HEX HEAD SCREWS



Skip pre-drilling and enjoy fast starts with CAMO Hex Head Multi-Purpose Screws. These code-compliant screws replace traditional lag screws and through-bolts in projects like deck posts, beams, and other general construction projects.

**SIZES:**

1/4 in Diameter Lengths:

<b>1½ in</b> (38.1mm)	<b>3 in</b> (76.2mm)	<b>4 in</b> (101.6mm)	<b>6 in</b> (152.4mm)
--------------------------	-------------------------	--------------------------	--------------------------

5/16 in Diameter Lengths:

<b>8 in</b> (203.2mm)	<b>10 in</b> (254mm)	<b>12 in</b> (304.8mm)
--------------------------	-------------------------	---------------------------

**FEATURES:**

- PROTECH® Ultra 4 Coating and Hot-Dip Galvanized options
- Code listed per DrJ TER No. 2102-01, 2404-04 and State of Florida FL 41741
- Replaces traditional lag screws and through-bolts
- For deck blocking, deck posts, beams, and railings, gardening and landscaping projects, and general construction applications



DECK POSTS, BEAMS + RAILINGS



GARDENING + LANDSCAPING PROJECTS



GENERAL CONSTRUCTION



DECK JOISTS

# 5/16" MULTI-PLY + LEDGER FLAT HEAD SCREWS



Make your multi-ply and ledger connections easier, faster and BETTER with CAMO Multi-ply and Multi-Ply + Ledger Screws. Code-compliant and exterior-coated, our multi-ply screws hold strong and finish flush in a variety of multi-ply, ledger, and general construction applications.

**SIZES:**

General Multi-Ply Lengths:

<b>2⅞ in</b> (73mm)	<b>4½ in</b> (114.3mm)	<b>6 in</b> (152.4mm)	<b>6¾ in</b> (171.5mm)
------------------------	---------------------------	--------------------------	---------------------------

Multi-Ply+Ledger Lengths:

<b>3½ in</b> (88.9mm)	<b>4 in</b> (107.6mm)	<b>5 in</b> (127mm)
--------------------------	--------------------------	------------------------

**FEATURES:**

- PROTECH® Ultra 4 Coating
- Code listed per DrJ TER No. 2102-01, 2102-02, 2102-04, 2404-04 and State of Florida FL 41741
- Replaces nailing patterns that don't always draw the wood together
- Replaces 1/2 in lag screws in general construction
- For fastening multi-ply wood headers and beams, ledgers, deck posts and handrails, and general construction projects



LEDGER BOARD CONNECTIONS



DECK BLOCKING



DECK POSTS, BEAMS + RAILINGS



GARDENING + LANDSCAPING PROJECTS



GENERAL CONSTRUCTION



MULTI-PLY BEAMS



# TRUSS SCREWS

EASY INSPECTION  
**HI-VIS**



Make your connections easier, faster and BETTER with CAMO Truss Screws. Code-compliant and exterior-coated, our truss screws are the ideal replacement for hurricane ties in general construction and decking applications.

**SIZE:**

6 in

(152.4mm)

4.5 in

(114.3mm)

**FEATURES:**

- PROTECH® Ultra 4 Coating (Tan only)
- Code listed per DrJ TER No. 2102-01 and 2102-03 and State of Florida FL 41741
- Fasten at the right angle with the included easy-to-use truss guide in every pail (6 in only)
- Replaces hurricane ties (6 in only)
- For use with truss and rafters to top plate, stud to top plate, and deck joists to beam applications (6 in only)
- For stud to bottom plate connections over masonry or concrete, and sole plate to rim board connections (4.5 in only)



TRUSS + RAFTER TO TOP PLATE



DECK JOIST TO BEAM



STUD TO DOUBLE TOP PLATE



SOLE PLATE TO RIM BOARD CONNECTIONS



STUD TO BOTTOM PLATE CONNECTIONS OVER MASONRY OR CONCRETE



INCLUDED TRUSS GUIDE (6 IN ONLY)

# DRILL SETTINGS FOR STRUCTURAL SCREWS

**A** CHOOSE YOUR DRILL



DON'T USE IMPACT DRIVER



Use an 18V drill or higher. Do not use an impact driver.

**B** INSERT BIT



Insert the bit supplied with the screws.

**C** ADJUST DRILL



Set drill to low speed. Turn up torque to the highest setting.

To Fasten Structural Screws, Follow the instructions in the DRJ Technical evaluation report for your specific screw and application.

# WHAT CAMO FASTENERS ARE MADE OF

## RECOMENDED USE

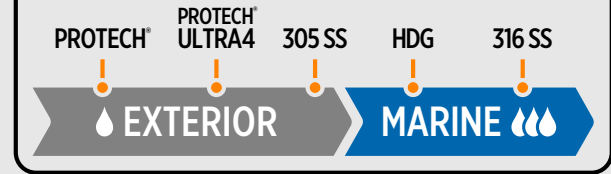

Building a deck or tackling any project with CAMO fasteners means **building better**. CAMO fasteners start **fast**, create **strong connections**, and **hold up to the elements** over time, thanks to their coating and alloys.

Learn more about each option below so **you can be confident** you've got the right fastener for your project and gain **peace of mind** knowing that they are all **backed by a CAMO Warranty**.

**!** WARNING: Failure to install CAMO fasteners in accordance with this installation guide may affect fastener performance and void product warranty.

## PROTECH®



PROTECH is our proprietary coating for our steel screws. It is suitable for use with pressure treated lumber, PVC, composite, and capped composite deck boards in inland environments that face regular exposure to the elements. Our **PROTECH-coated fasteners are guaranteed against rust and corrosion for the life of your project** so long as they are installed following CAMO recommendations.

### PROTECH-COATED FASTENERS ARE SUITABLE IN MANY APPLICATIONS:

- Decks, patios, and structures in inland areas away from water
- Installations of pressure treated, PVC, composite, and capped composite boards
- Exterior projects in temperate climates that face typical weather events

## PROTECH® ULTRA 4 COATING



Our proprietary PROTECH Ultra 4 four-layer coating system protects your connections against the harshest environmental elements. Each layer works together to provide optimum corrosion resistance, UV and environmental protection, and torque reduction for a high-performing, long-lasting screw. Tested in accordance with ASTM G198, the coating meets or exceeds the protection of code-approved hot-dip galvanized (ASTM A153, Class D) in ground contact general use pressure treated lumber (AWPA UC1-UC4A).

### PROTECH ULTRA 4-COATED FASTENERS ARE SUITABLE IN MANY APPLICATIONS:

- For interior and exterior projects where corrosion resistance is key
- Structural projects that utilize a larger screw with a greater surface area, coming in contact with more wood
- Installations with ground contact general use pressure-treated lumber

## 305 STAINLESS STEEL \*



If your project is outside of 3,000 feet from a saltwater shoreline, Stainless Steel fasteners are recommended, and CAMO 305 Stainless Steel fits the bill. 305 Stainless Steel **offers better resistance against corrosion** than a carbon coating and **will keep your project safe and long-lasting** while offering excellent aesthetics. Widely available across the country, 305 Stainless Steel is a great alloy option for installing pressure treated lumber, PVC, composite, and capped composite deck boards no matter where you are located.

### 305 STAINLESS STEEL IS GREAT FOR A VARIETY OF APPLICATIONS:

- Exterior structures 3000 feet to 10 miles from a saltwater shoreline
- Installations of pressure treated, PVC, composite, and capped composite boards
- Any outdoor project that you want to protect against potential corrosion

## HOT-DIP GALVANIZED



A small step under Stainless Steel in terms of corrosion protection, hot-dip galvanized coating is a viable and reliable option for various fasteners. The code-approved coating is tested to meet ASTM A153, Class D, and is approved for use in MCA ground contact pressure treated lumber.

The hot-dip galvanization process results in a thick coating that will wear over time but still offer excellent protection against corrosion for the lifetime of the exterior application. Additionally, the coating is applied uniformly, so your connections are completely protected.

### HOT-DIP GALVANIZED COATING IS COMMONLY USED IN THE FOLLOWING APPLICATIONS:

- Exterior projects in temperate climates that you want to protect against the elements
- Structural projects that utilize larger screws with a greater surface area, coming in contact with more wood
- Coastal applications where salt water can cause severe corrosion

## 316 STAINLESS STEEL \*



316 Stainless Steel is the best fastener for any project and is required for installations in highly corrosive areas, so your build remains structurally sound and aesthetically pleasing.

Saltwater environments present an opportunity for severe rust and corrosion, so 316 Stainless Steel is required in any coastal, marine, or waterway area within 3,000 feet of saltwater. We also recommend using 316 Stainless Steel in structures within a 10-mile reach of saltwater, which are susceptible to increased corrosion rates as saltwater is aerosolized.

### 316 STAINLESS STEEL IS RECOMMENDED IN A VARIETY OF APPLICATIONS BEYOND SALTWATER EXPOSURE:



- Structures near swimming pools where the surface will be exposed to chlorine
- Agricultural environments that deal with chemicals, pesticides, and treatments
- Decks, patios, and structures that will face wood strippers or ice-melting chemicals
- Installations of cedar, redwood, or hardwood decking where tannin release caused by carbon fasteners may cause staining and streaking

If you want to install following best practices and never have to think or worry about your fastener holding up, choose 316 Stainless Steel for every exterior job.

*\* Stainless steel is not corrosion-proof; it is corrosion-resistant and staining can still occur. It is important to regularly wash the installed screws to keep the heads and screw recesses clean from salt deposits and other residue.*



# RESOURCES

From Edge fastening in special cases to troubleshooting your DRIVE tool and more, this resource section contains the information you need to tackle any install.

SPECIAL CASES - EDGE FASTENING	53
BEST PRACTICES FOR EDGE FASTENING	55
INSTALLATION RECOMMENDATIONS BY BOARD TYPE	56
SPECIAL CASES - CLIP FASTENING	60
TROUBLESHOOTING	62



# Edge Fastening Against a Structure

## BY HAND & WITH DRIVE

Given the length of the DRIVE tool and the angle required for installation, you will not be able to Edge fasten both sides of the first few rows of boards next to a structure. In these instances, use CAMO Premium Deck or Composite Screws following the instructions below.

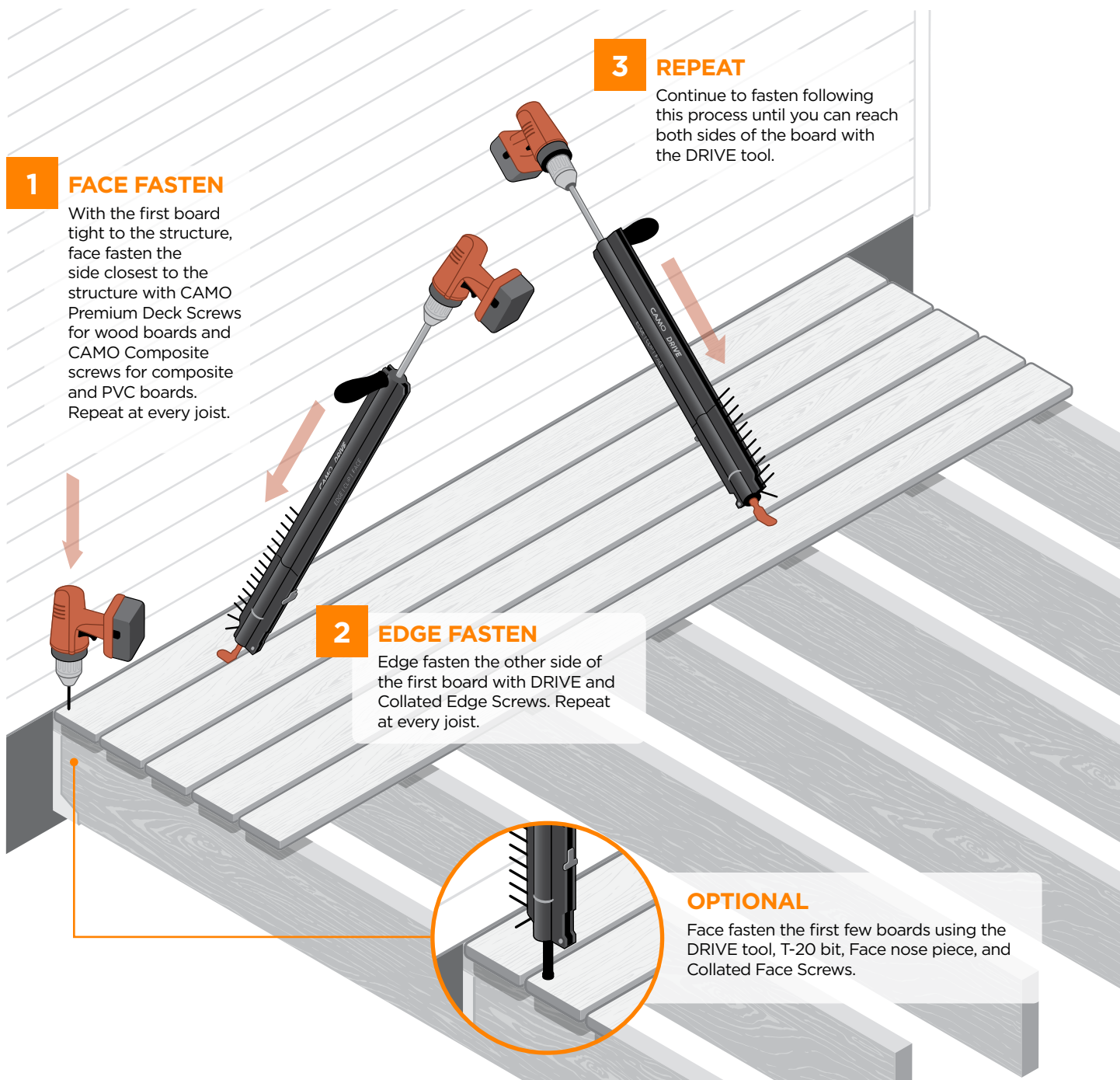

### 1 FACE FASTEN

With the first board tight to the structure, face fasten the side closest to the structure with CAMO Premium Deck Screws for wood boards and CAMO Composite screws for composite and PVC boards. Repeat at every joist.

### 3 REPEAT

Continue to fasten following this process until you can reach both sides of the board with the DRIVE tool.

### 2 EDGE FASTEN

Edge fasten the other side of the first board with DRIVE and Collated Edge Screws. Repeat at every joist.

### OPTIONAL

Face fasten the first few boards using the DRIVE tool, T-20 bit, Face nose piece, and Collated Face Screws.



# Edge Fastening Against a Structure

## MARKSMAN® TOOLS

Given the drill angle required for installation with the MARKSMAN Pro® Tools, you will not be able to Edge fasten both sides of the first board next to a structure. In these instances, use CAMO Premium Deck or Composite screws, following the instructions below.

### 1 FACE FASTEN

With the first board tight to the structure, face fasten the first board with CAMO Premium Deck Screws for wood boards and CAMO Composite screws for composite and PVC boards. Repeat at every joist.

### 2 BEGIN EDGE FASTENING

Once you can fit your drill on both sides of the MARKSMAN tool, start Edge fastening the board.

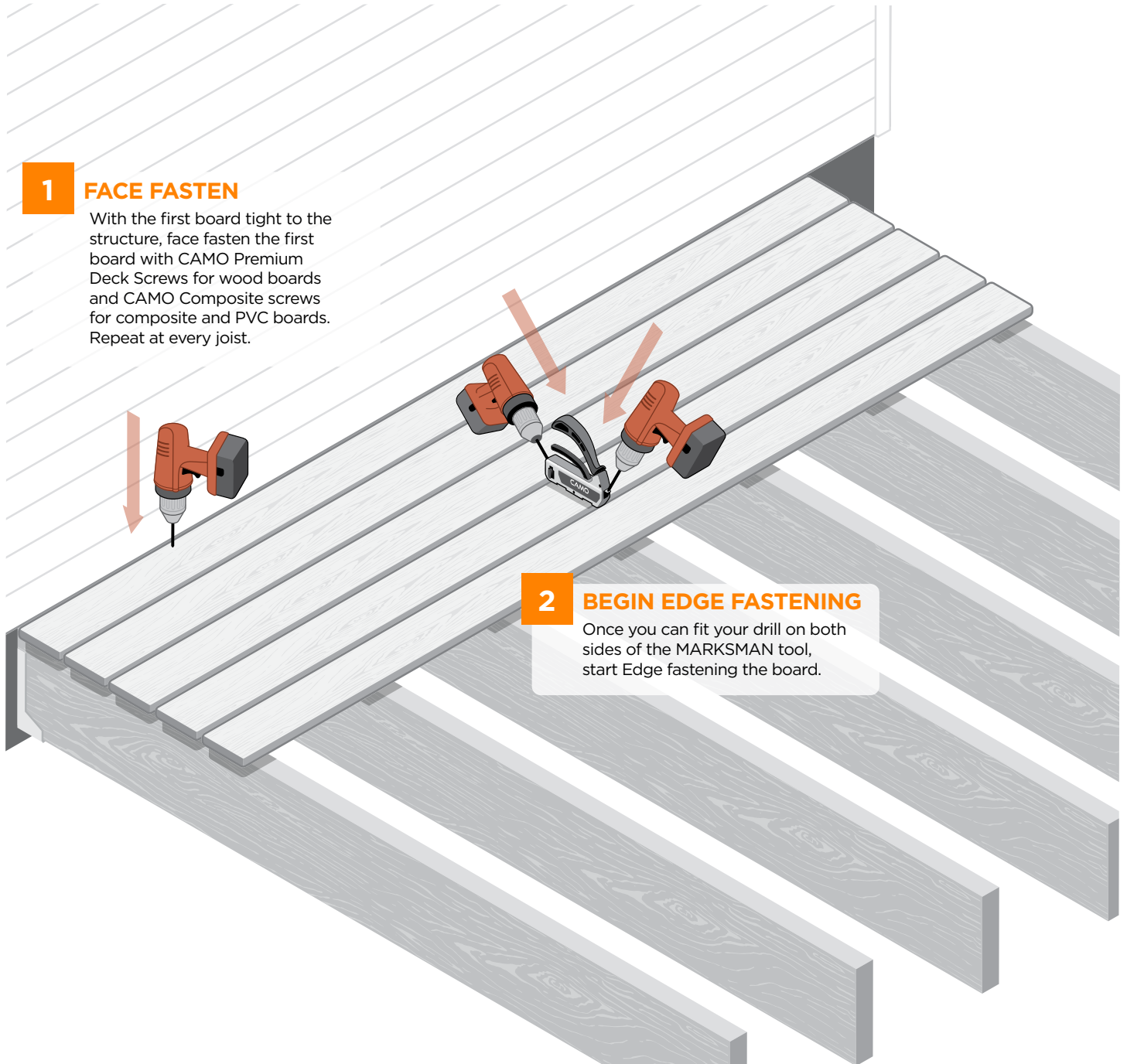



# Best Practices for Edge Fastening

 Failure to install CAMO Edge Screws in accordance with this installation guide may affect fastener performance and void product warranty.

 CAMO Edge Screws are intended for attaching deck boards directly to deck substructure using CAMO tools. Any other use is not recommended or covered by warranty.

## GUIDELINES FOR EVERY EDGE FASTENING INSTALLATION

### DECK SLOPE:

Your deck surface should be sloped a minimum of 1/4 in per 12 feet of horizontal run to allow for moisture run-off.

### AIRFLOW/DRAINAGE:

You must have unobstructed airflow under 50% of the deck to allow for sufficient cross-ventilation from one side to the other. This allows the underside of the deck structure to dry and prevents heat build-up. Never install a deck directly over any solid surface, such as concrete.

### INSTALL DOUBLE (SISTER) JOISTS:

A double joist is required at butt joints where two board ends meet on the deck surface.

### FROWN DOWN:

When you look at the wood deck board ends, you will see the lumber's growth rings. Make sure those rings are facing downward—the direction of a frown—when laid flat on the joists for fastening. This will reduce the natural tendency for the board to cup upward when it dries.

### FASTENING:

- Do not fasten within 1 in of the deck board ends.
- Use two screws on every board at each joist location.
- Do not force the Edge screw. Allow the Edge screw to scrape and auger the surface with light pressure, which allows the Edge screw to enter the board without splitting.
- Never use CAMO Edge screws to attach decking to a floating substructure.

## SELECTING THE RIGHT EDGE SCREW

Edge screws are available in two sizes:

- 1<sup>7</sup>/<sub>8</sub> in for boards 1 in thick or less
- 2<sup>3</sup>/<sub>8</sub> in for boards thicker than 1 in

Edge screws are available in PROTECH® Coating and 316 Stainless Steel.



DECK BOARD MATERIAL	RECOMMENDED CAMO EDGE SCREW
Pressure Treated Lumber	Stainless Steel or PROTECH Coated
Composite	Stainless Steel or PROTECH Coated
Capped Composite	Stainless Steel or PROTECH Coated <b>(with partial pre-drill)</b>
PVC	Stainless Steel Required
Cedar	Stainless Steel Required
Redwood	Stainless Steel Required
Hardwood or Imported Hardwood	Stainless Steel Required <b>(with partial pre-drill)</b>

# Recommendations by Board



## PRESSURE TREATED

Twisting, warping, cupping, and splitting are expected performance attributes with pressure treated decking in its wet/green state. Following the guidelines presented will reduce, but not eliminate, the normal behavior of pressure treated deck boards.

- **Board Spacing:** Typical pressure treated decking (moisture content above 19%) needs little to no spacing between boards at the time of installation. As the boards dry, they will shrink, creating a space naturally.
- **Installing on Sleeper Systems:** CAMO Edge Screws are not recommended for sleeper systems using treated lumber.
- **Recommended CAMO Tools:**
  - DRIVE (no gap)
  - MARKSMAN® EDGE (no gap)
  - MARKSMAN Pro®-X1 (1/16 in gap)



## COMPOSITE DECKING

Air temperature variation results in the expansion and contraction of various boards, including composite. Following the guidelines presented will ensure the best installation and reduce problems associated with board movement.

- **Board Spacing:** Always review and follow your deck manufacturer's gap and spacing requirements for deck board installation. These requirements can vary by manufacturer and installation temperature and environment.
- **Installing on Sleeper Systems:** You must allow a 1-1/2 in minimum of unobstructed airflow beneath the deck on both ends in the direction that the joist runs and have at least 3/16 in board spacing.
- **Recommended CAMO Tools:**
  - MARKSMAN Pro® (3/16 in gap)
  - CLIPDRIVE™ with clips on grooved boards
  - DRIVE (with secondary 3/16 in spacer)



## KDAT (KILN DRIED AFTER TREATING)

Twisting, warping, cupping, and splitting are expected performance attributes with KDAT decking. Following the guidelines presented will reduce, but not eliminate, the normal behavior of pressure treated deck boards.

- **KDAT weatherization treatment:** KDAT must always be sealed with a water repellent with UV protection before or immediately after installation.
  - Stain: Use a penetrating stain with water repellent and UV stabilizer.
  - Paint: Use an oil-based primer followed by two coats of latex (acrylic) paint.
- **Board Spacing:** Install KDAT decking with a minimum of 3/16 in spacing between boards. KDAT boards are installed in a thirsty state and will expand slightly as they are exposed to moisture.
- **Installing on Sleeper Systems:** You must allow a 1-1/2 in minimum of unobstructed airflow beneath the deck on both ends in the direction that the joist runs.
- **Recommended CAMO Tools:**
  - MARKSMAN Pro® (3/16 in gap)
  - DRIVE (with secondary 3/16 in spacer)

When you require the use of secondary spacers, use a couple of MARKSMAN tools to properly space your boards before fastening with DRIVE. They also come in handy in tight fastening situations.

# Recommendations by Board



## PVC DECKING

Air temperature variation results in the expansion and contraction of various boards, including PVC. Following the guidelines presented will ensure the best installation and reduce problems associated with board movement.

- **Acclimating:** Boards should be kept at ambient temperature and shaded from direct sun prior to cutting and immediate fastening.
- **Board Spacing:** Always review and follow your deck manufacturer’s gap and spacing requirements for deck board installation. These requirements can vary by manufacturer and installation temperature and environment.
- **Board Size:** Because of the potential for linear expansion and contraction from temperature variance, use shorter board lengths where possible.
  - Use a breaker board design to shorten board runs.
  - End-To-Side board spacing (Where deck board end meets fixed breaker or picture frame board) see chart below
  - For board runs 16’ and longer, face fasten at the midpoint and at both ends of the boards with color matched stainless steel composite screws. (Plug systems are acceptable)
- **Installing on Sleeper Systems::** You must allow a 1-1/2 in minimum of unobstructed airflow beneath the deck on both ends in the direction that the joist runs and have at least 3/16 in board spacing
- **Recommended CAMO Tools:**
  - MARKSMAN Pro. (3/16 in gap)
  - DRIVE (with secondary 3/16 in spacer)
  - CLIPDRIVE™ with clips for grooved boards
  - AZEK SIDELOC Guide (1/8 in gap)

### END-TO-SIDE BOARD SPACING BY INSTALLATION TEMPERATURE

70 Degrees and below	71 Degrees and above
3/16" (5mm)	1/8" (3.2mm)



# Recommendations by Board



## CAPPED COMPOSITE

Air temperature variation results in the expansion and contraction of various boards, including capped composite. Following the guidelines presented will ensure the best installation and reduce problems associated with board movement.

- **Board Spacing:** Always review and follow your deck manufacturer's gap and spacing requirements for deck board installation. These requirements vary depending on the specific board material.
- **Installing on Sleeper Systems:** You must allow a 1-½ in minimum of unobstructed airflow beneath the deck on both ends in the direction that the joist runs and have at least 3/16 in board spacing.
- **Recommended CAMO Tools:**
  - MARKSMAN Pro® (3/16 in gap)
  - CLIPDRIVE™ with clips on grooved boards
- **Pre-drilling is Required:** Use the pre-drill process when installing capped composite boards to eliminate mushrooming and splitting.
  - Use CAMO 3/16 in pre-drill bit (item #345035) with your MARKSMAN Pro Tool in place on the deck board.



You can also use your own 3/16 in drill bit chucked at 2-¾ in from the nose of the drill

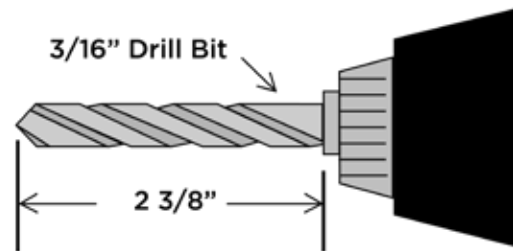

## CEDAR AND REDWOOD

Cedar and Redwood are stable deck boards. They naturally resist moisture which causes splitting, twisting, and cupping. Following the guidelines presented will ensure the best performance.

- **Board Spacing:** We recommend 1/8 in to 1/4 in spacing between boards at the time of installation.
- **Installing on Sleeper Systems:** You must allow a 1-½ in minimum of unobstructed airflow beneath the deck on both ends in the direction that the joist runs and have at least 3/16 in board spacing.
- **Recommended CAMO Tools:**
  - MARKSMAN Pro® (3/16 in gap)
  - DRIVE (with secondary 3/16 in spacer)

# Recommendations by Board



## TROPICAL HARDWOOD

Twisting, warping, and cupping are common performance attributes with hardwood decking. Following the guidelines presented will reduce, but not eliminate, the normal behavior of hardwood deck boards.

- **Acclimating:** Tropical hardwood decking needs to be acclimated to the environment prior to installation.
  - We recommend that the boards be on-site at least 7 days prior to installation.
  - Do not store directly on the ground or on top of concrete. Decking should be elevated at least 12 in off the ground.
  - Cover the material with a sheet of plywood to keep it dry until installation. Do not use a tarp or plastic as a cover as both can trap moisture.
  - Place 1 in x shims/stickers between the rows of boards to allow for airflow.
- **Board Spacing:** A minimum of 1/16 in spacing is required to allow for expansion and contraction. Expect 1/8 in-1/4 in of side-to-side board shrinkage.
- **Installing on Sleeper Systems:** Typical sleeper systems will not meet the minimum airflow requirements for hardwood installation, so they are not recommended.
- **Cutting:** Board ends should be sealed with end grain sealant within 24 hours of cutting.
- **Recommended CAMO Tools:**
  - MARKSMAN Pro® (3/16 in gap) for the best experience
  - MARKSMAN Pro\*-X1 (1/16 in gap) for minimal spacing
  - CLIPDRIVE™ with clips on grooved boards
- **Pre-drilling is Required:** Use the pre-drill process when installing hardwood boards to eliminate pushout and splitting.
  - Use CAMO 3/16 in pre-drill bit (item #345035) with your CAMO MARKSMAN Pro or Pro-X1 Tool in place on the deck board.



You can also use your own 3/16 in drill bit chucked at 2-3/8 in from the nose of the drill

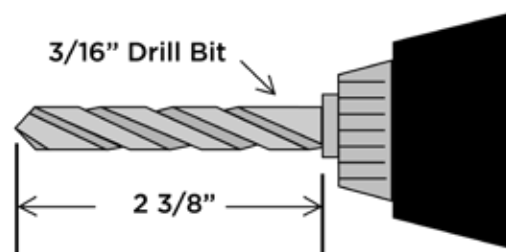

# Installing at Butt Joints

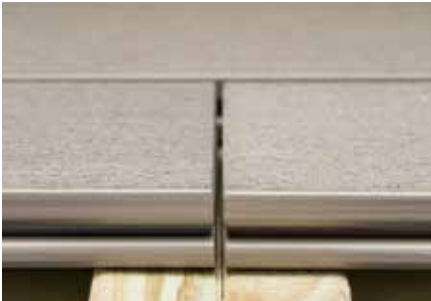

## ALWAYS INSTALL A DOUBLE JOIST AT THE BUTT JOINTS

Use a separate clip to secure each board end. Please follow your deck board manufacturer's instructions for end-to-end board gapping distance to allow for expansion and contraction at this joint.

### EDGE CLIPS

1



#### REMOVE LEGS ON EDGE CLIP

You will need 4 clips for each butt joint. Remove the legs of the Clip so that they can sit side-by-side on the double joists.

2



#### FASTEN SCREWS

With boards positioned correctly, place the clips in the groove, centered on joists on both sides of the boards. Partially fasten the screws to hold them in place until next board is set, then fully fasten the screws.

### WEDGE & WEDGEMETAL CLIPS

1



#### PLACE 4 CLIPS

Place 4 Clips centered on joists on both sides of the boards.

2



#### FASTEN SCREWS

Place the next board up against the clips, then fasten the screws.



# Replacing Boards If Needed

1

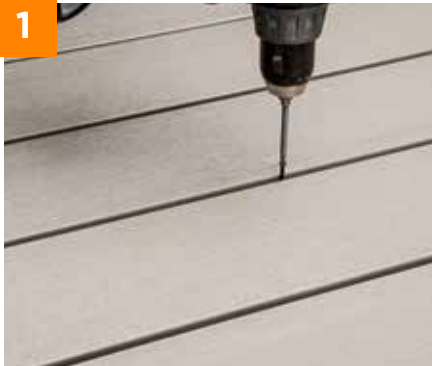

## BACK OUT SCREWS

Back out all of the screws from the joist on both sides of the board.

2



## PULL UP BOARD

Pull up on the board to easily remove it.

3



## LAY NEW DECK BOARD

Clean away any clips remaining on the joists and lay the new deck board in position without any clips in place.

4



## REMOVE LEGS

Count the number of clips needed and snap off the legs on each EDGE Clip, if using.

5



## SLIDE CLIPS DOWN GROOVE

Slide the clips (screws and gussets) down the groove positioning one over each joist on both sides of the board.

6



## FASTEN AT EACH JOIST

Fasten clips securely in place using the NEVER-MISS® Guide.

# Troubleshooting

## REMOVING COLLATED SCREWS FROM DRIVE

1



### SLIDE PICKER

Slide the picker up to the nose piece to release tension.

2



### REMOVE STRIP

The strip should easily pop free, or you can pull it out.

## UNJAMMING COLLATED STRIPS

1



### RELEASE STRIP

Slide picker up to release the strip from the picker.

2



### BACK OUT OR TEAR STRIP

If possible, back out the strip from the nose piece. If you can't back it out, tear the strip away from the jammed fastener.

3



### REMOVE NOSE PIECE

Remove the nose piece to ensure it's clear of fasteners.

4



### REATTACH

Insert the nose piece again

5



### RELOAD

Load a new strip of screws.

## WHEN TO CHANGE THE BIT



### DRIVER BITS AND THE BIT HOLDER WILL WEAR OVER TIME.

**If you hear a grinding sound while driving, the bit may be slipping in the bit holder**

- Check the bit tip for wear and replace it if it's worn.
- If the bit tip is fine, check the bit at the top where it locks into the bit holder.
- If there is a wear line at the top of the bit, it's time to change the bit holder.

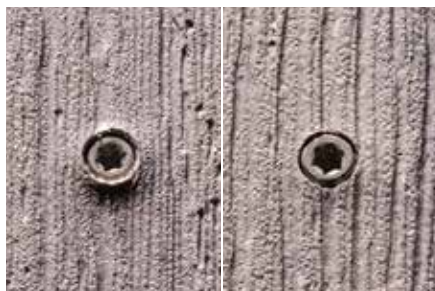

**If you're experiencing screws not driving fully flush:**

- Check the depth dial—it's possible it was bumped.
- Make sure you're using the correct bit.
- Check the bit tip for wear and replace it if it's worn.
- If there is a wear line at the top of the bit, it's time to change the bit holder.



We do not recommend the use of impact drivers as they will cause driver bits to wear quickly and even crack.

## BOARDS ARE CRACKING WHEN FASTENED



### Edge Fastening

- If you are applying too much pressure on the drill it prevents the screw from boring the material. This can cause screw slipping and mushrooming with PVC and composite boards, or cracking and splitting of wood boards.
- Solution: let the rake tip on the screw auger the material out—do not force it.

### Composite Face Fastening

- If you are applying too much pressure, the composite boards can mushroom and crack.
- Solution: let the sharp point of the screw do the work of biting into the board—do not force it. Additionally, the trilobular shank will reduce torque and prevent mushrooming.

## CLIP SCREWS ARE STRIPPING

Excessive torque can cause over-driving, resulting in screw spin-out or stripping. Be sure your drill (not impact driver) is set to lowest torque setting and only increase as necessary. Also, be sure to check the tip on your bit for wear if screws continue to strip and replace it if it's worn.





**CAMO**<sup>®</sup>

**The Better Way to Build a Deck**

FOR MORE INFORMATION, VISIT [CAMOFASTENERS.COM](http://CAMOFASTENERS.COM) OR  
CONTACT US AT 800-968-6245 OR [INFO@CAMOFASTENERS.COM](mailto:INFO@CAMOFASTENERS.COM).

ITEM #0345989